

Digital Preamplifier / Matrix 8 inputs / 2 outputs



Description

Mixer preamplifier with 8 convertible microwave auxiliary inputs (INPUT1 INPUT-8) and 2 outputs level 0 dBu (OUTA, OUT B).

The PX-99 is used to assign each input to output A, output B or both (option C), acting as a matrix of 8 inputs / 2 outputs, with total flexibility.

Each input can be configured as balanced microphone or as an auxiliary unbalanced.

The microphone inputs have phantom supply and configurable password filter.

Each entry has: volume control, independent bass and treble. Assignable priority level to level 1 (minimum level of priority) to 8 (maximum) for the automatic control signal.

VOX function. Each entry has a level sensor with an adjustable threshold (0 to 50), so when the signal exceeds the trigger level, the channel opens. This can also be used as an automatic switch signal, and as a noise gate.

At each entrance, together with the VOX function (and with priority level greater than 1) we can assign the remote function. When the VOX function of this input is activated besides open the audio channel, will be a remote contact closure to ground (open collector) in the remote output terminals, A or B as appropriate entry

In each output A and B offers master volume independent.

The outputs can adjust the level to 0 dB and -6 dB.

The device, in addition, has a limitation that prevents the saturation level in the output.

Possibility of inserting a coupler module WX-19 in each output. It also has two sets of keys (treble) / (bass) called F1 and F2, which can be assigned to any volume control, whether a particular input or master.

To configure the PX-99 is necessary to go into the USER MODE. During configuration (volume tones, VOX, etc...), the device operates in real time, offering the result of what is done.

Once the installation and the configuration are done, leave the technical mode. The device is in USER MODE.

When you use the display it will show two bars as a vumeter.

In USER MODE can influence the volume settings of the bass and treble for each entry.

In addition, at any time, can act directly on the F1 and F2, which will act on what they have assigned.

The new settings are stored in non-volatile memory. It means that when you remove and replenish the system, they remain in it.

Technical characteristics

- 8 inputs for configurable micro / aux (XLR).
- 2 Outputs 0 dBu (XLR).
- Volume and tone control independent for each input.
- VOX detector with adjustable threshold for each input.
- Priority configuration input.
- Assigning inputs for each output. Configurable.
- 2 Function keys.
- Alphanumeric display 2x16 characters.

REMOTE CONTROL PROGRAM SF-99

The preamplifier PX-99 has a remote control program named SF-99, to run in PC, and it is possible to download it from website www.udeaudio.com. Using this software and connection cable USB type B, you can configure all characteristics of the amplifier: volume, bass and treble, auxiliary input, sensitivity and recuperation time of VOX control, inputs a outputs routing, priority, phantom power, keyword filter, remote control and attenuation of -6dB.

Also allows the record of one security copy of configurations for PX-99 installation, so is possible programming the equipment many times if is necessary.

Front panel

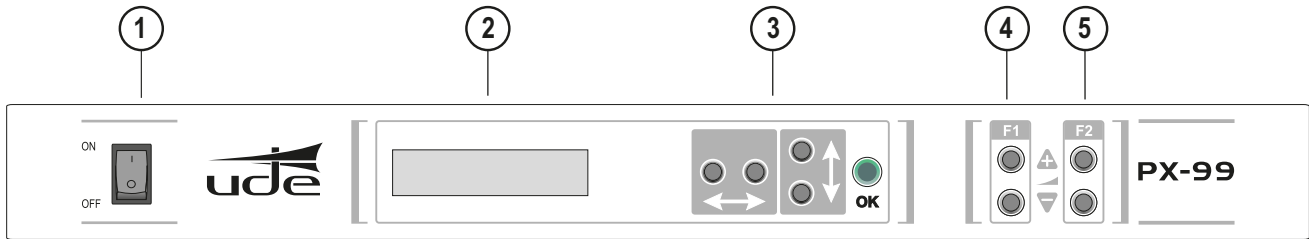

- ① ON / OFF switch
- ② Alphanumeric display. Vumeter.
- ③ Navigation keys.
- ④ Function keys F1.
- ⑤ Function keys F2.

Rear panel

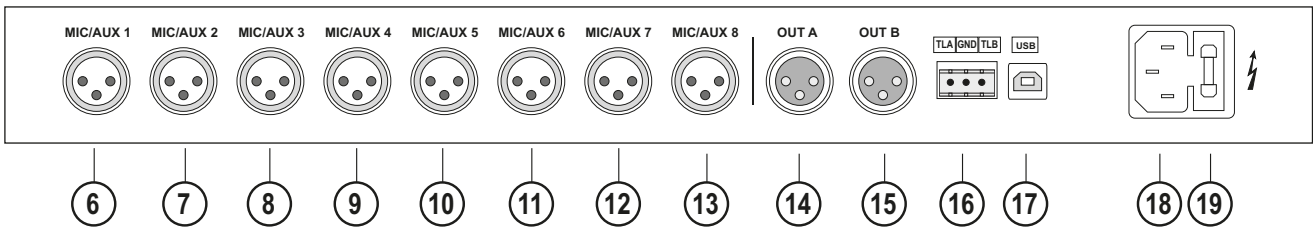

- ⑥ Micro / Aux Input 1 (XLR)
- ⑦ Micro / Aux Input 2 (XLR)
- ⑧ Micro / Aux Input 3 (XLR)
- ⑨ Micro / Aux Input 4 (XLR)
- ⑩ Micro / Aux Input 5 (XLR)
- ⑪ Micro / Aux Input 6 (XLR)
- ⑫ Micro / Aux Input 7 (XLR)
- ⑬ Micro / Aux Input 8 (XLR)
- ⑭ 0 dBm signal output A. (XLR)
- ⑮ 0 dBm signal output B. (XLR)
- ⑯ Remote outputs A-B
- ⑰ USB communication port
- ⑱ Electrical output 230 VAC.
- ⑲ AC Fuse T0,5A.

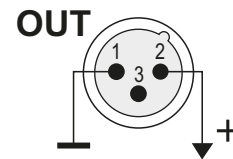
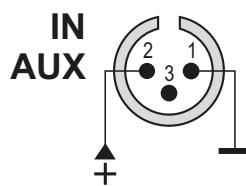
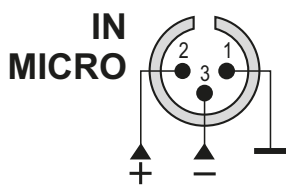

Technical characteristics

- Input MICRO sensitivity:	1 mV / 600 Ω (symmetric)
- Input AUX sensitivity:	100 mV / 50 k Ω (symmetric)
- Outputs sensitivity:	0 dBu / -6dBu.
- Tone controls:	Bass: 100 Hz. ± 10 dB. Treble: 10 KHz. ± 10 dB.
- Phantom power supply:	12 VDC.
- Word filter for microphone.	700 Hz.
- Frequency range:	50 Hz. to 18 KHz.
- Distortion:	Less than 0,1%.
- Maximum consumption:	10 VA.
- Power supply:	230 VAC (50/60 Hz).
- Dimensions:	427 x 43 x 314 mm. (1 U).
- Weight:	2,95 Kgs.

Input priority (factory setting)

Inputs 1-2-3-4-5-6

Microphone
Phantom supply
Word filter off
Without remote contro

Inputs 7-8

Auxiliary

All inputs:

Volume adjustment: 5
Bass and High: 0
Vox: +4
Priority: 1 (without priority)
Output assignment: A

Outputs:

Volume control: 5
F1 : Vol. Control MASTER A
F2: Vol. Control MASTER B
Output level 0 dBu

Block diagram

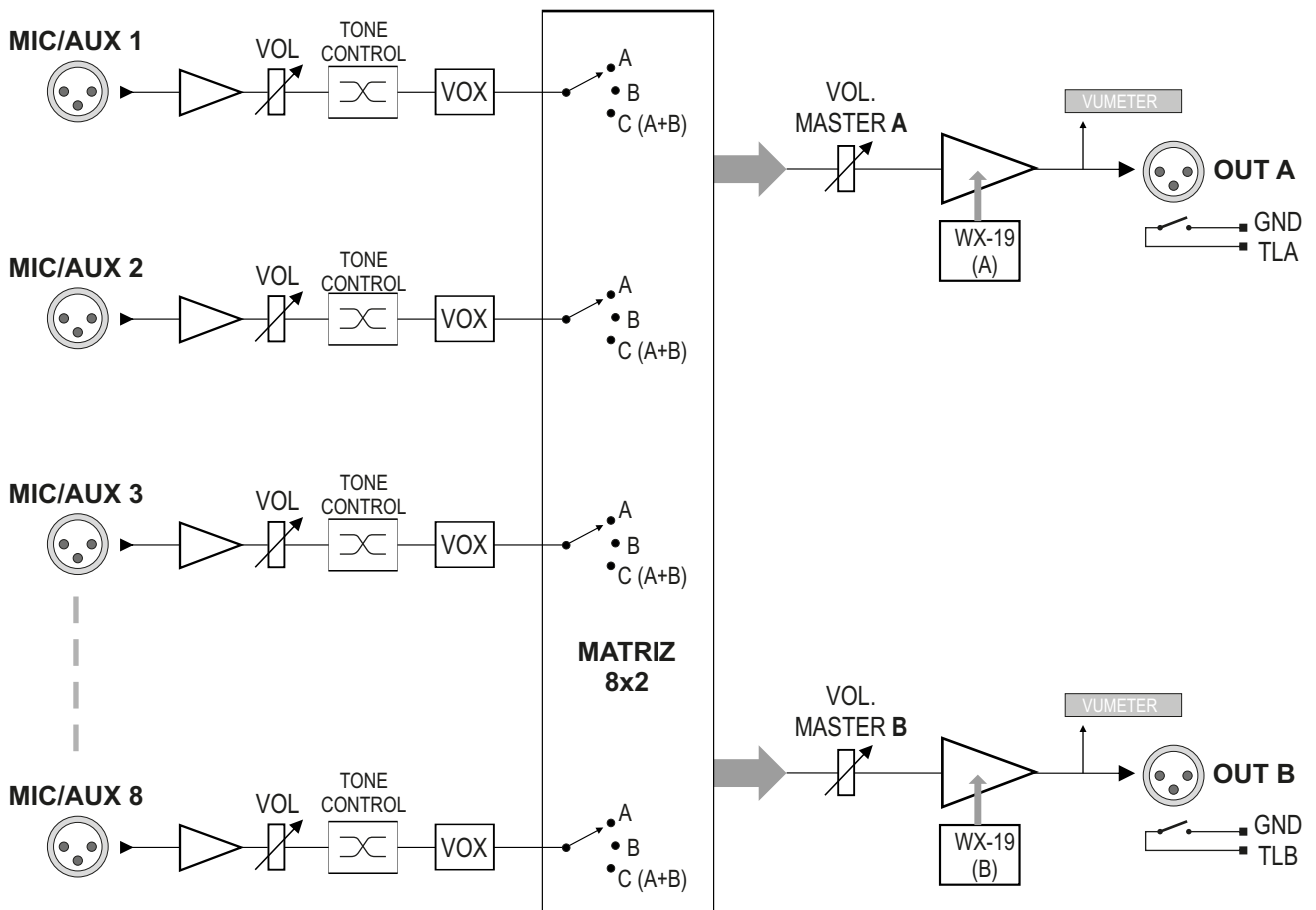

WX-19 module assembly

- 1 - Remove the cover of the unit
- 2 - Assemble the WX-19 in its position using the screws provided.
- 3 - Connect the 6 cables hose as shown
- 4 - Remove the bridge (D-A) or (D-B). Don't require further adjustments.
- 5 - Replace the cover.

NOTE:

When you remove the module **WX-19** device, it is necessary to restore the bridge (D-A) or (D-B) in place.

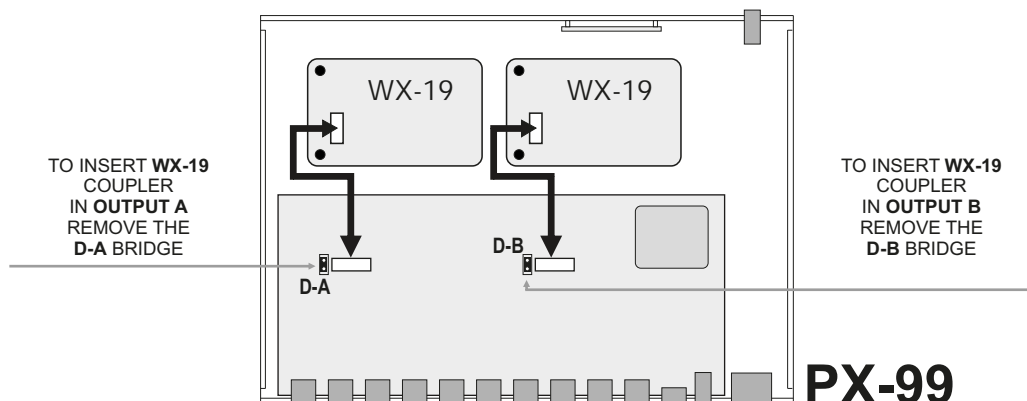

Acces to technical mode

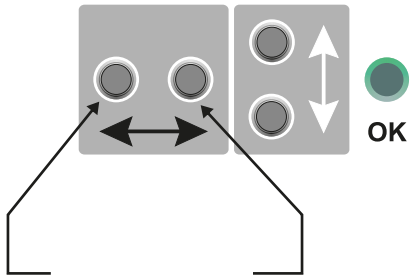

TO GO TO TECHNICAL MENU,
KEEP PRESSING
FOR 5 SECONDS
BOTH BUTTONS

HOME SCREEN



ENTER A 4 FIGURES PASSWORD (1 to 4)
BY NAVIGATION AND VALIDATE

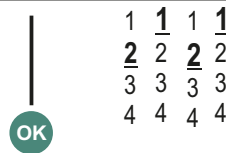

INPUTS
CONFIGURATION

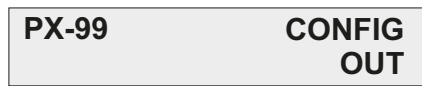

OUTPUTS
CONFIGURATION



EXTERNAL
CONFIGURATION

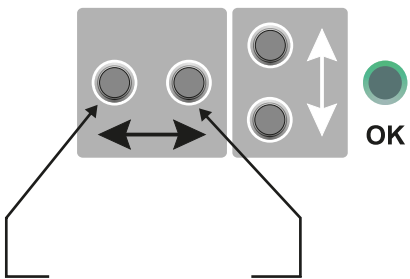

TO LEAVE TECHNICAL MENU,
KEEP PRESSING FOR 5 SECONDS
BOTH BUTTONS.

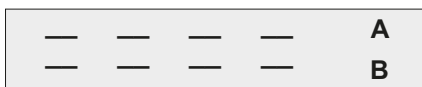

HOME SCREEN

Technical mode operation

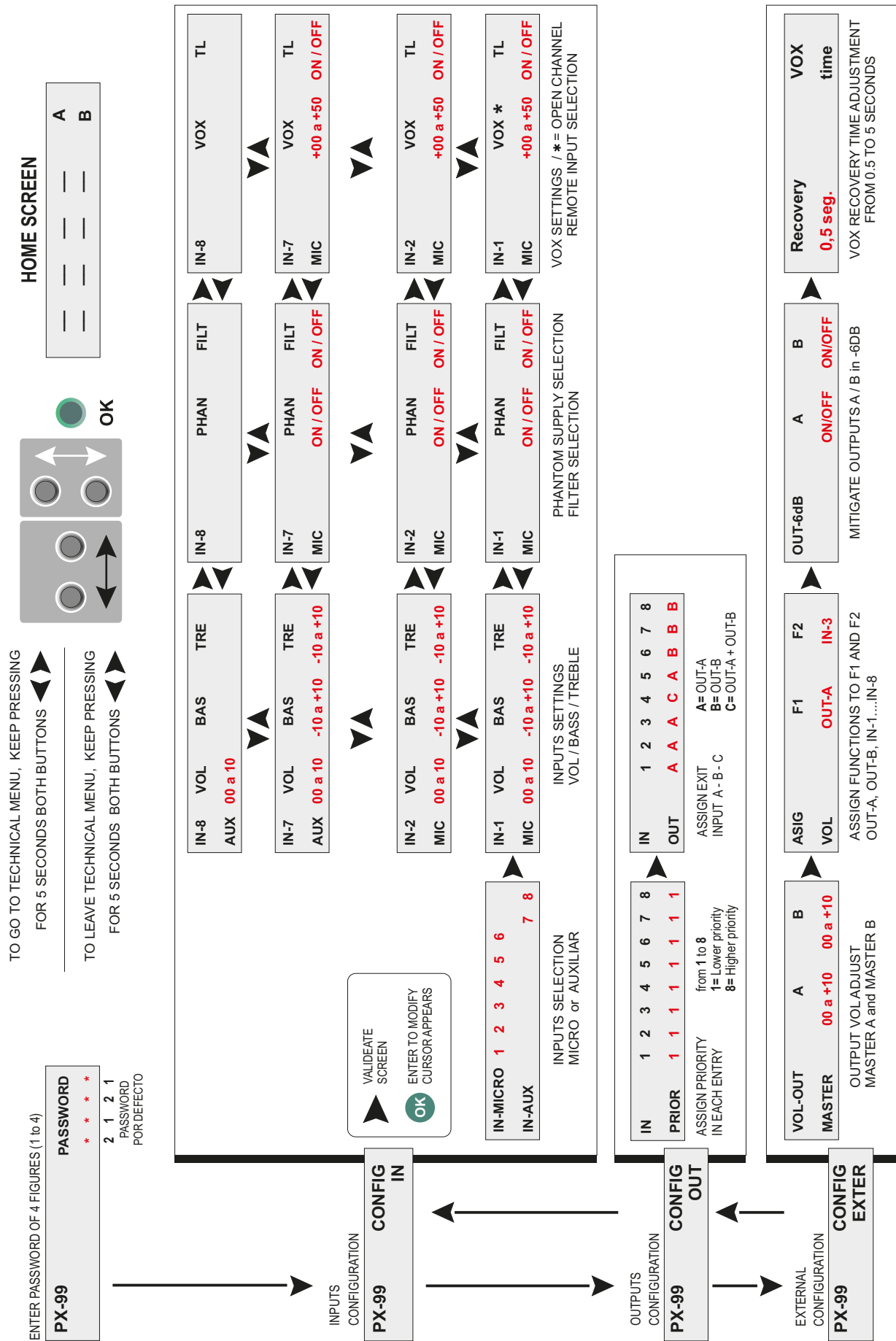

User mode operation

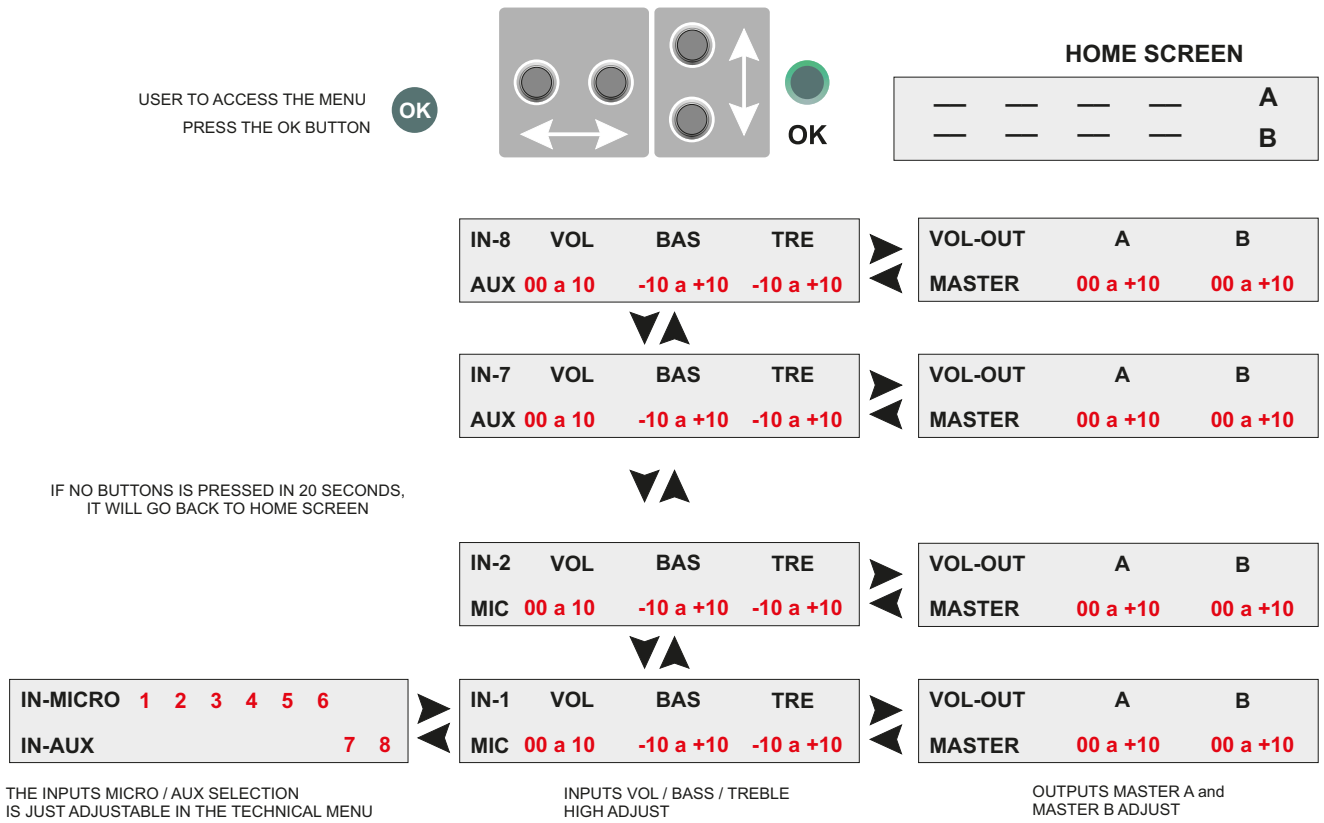

Modify / Validate parameters

