



Simultaneous, automatic and duplex intercom system (hands free), with built-in antilarson device.

It is specially useful to be used in spoken communication where glazing separates people communication from one side to another (in banks, prisons, train station, hospitals, telephone booths, etc...)



IV-6/M System

Composition:

- 1 PZ-39V Indoor microphone
- 1 IV-5 Outdoor microphone
- 1 WV-6 Central
- 1 WV-12 Power supply



Description

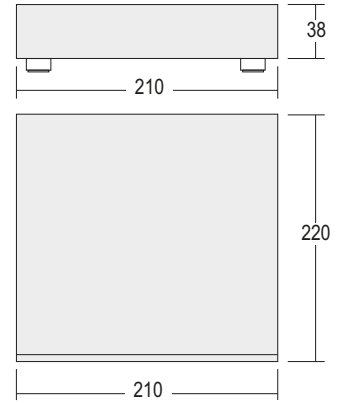
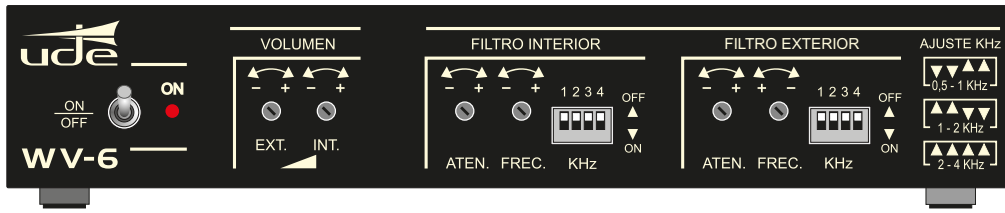

DIMENSIONES EN MILÍMETROS

DESCRIPTION

Thanks to its reduced dimensions, it is possible to mount it on a wall, on a table, and in a 19" rack with the WM-200 accessory.

Powered by a **WV-12 power supply** (100-240V AC / 12V DC).

It has a special anti-larsen device as well as two parametric filters for optimized performance.

It has a headphone output (inside the cabin) for a better privacy of the system, which are used with the PZ-39V inside.

ATTENTION: When the headphone jack is inserted, the speaker of the PZ-39V is disabled.

It also incorporates as standard a magnetic loop amplifier (ref. WV-10) to help the hearing impaired.

All this makes the WV-6 control unit a very flexible element to satisfy all cases of window intercommunication.

CONFIGURATION:

The system is configured by default for IV-5/M.

Mount the central unit in its location, considering that the various adjustment and connection elements must be accessible.

Configuration Main station WV-6 for systems: -IV-6/M -IV-5/M

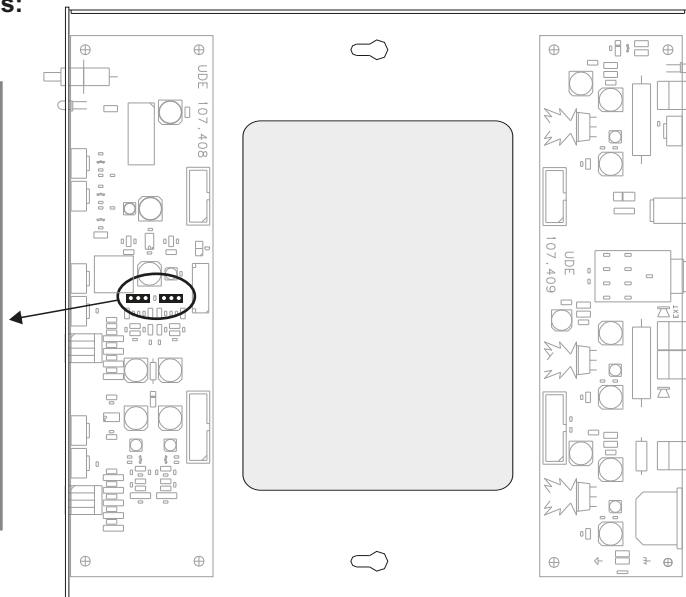
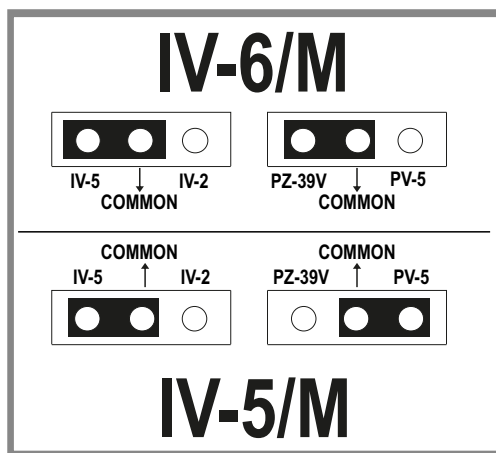

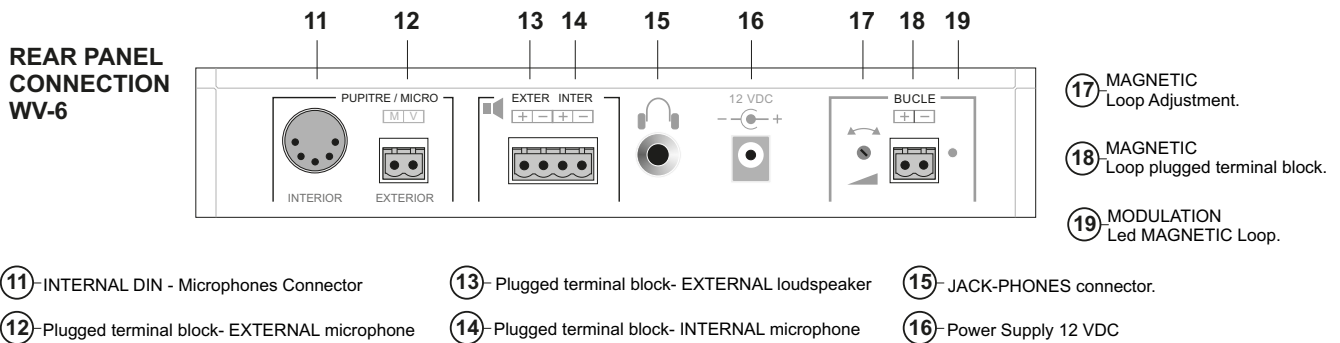
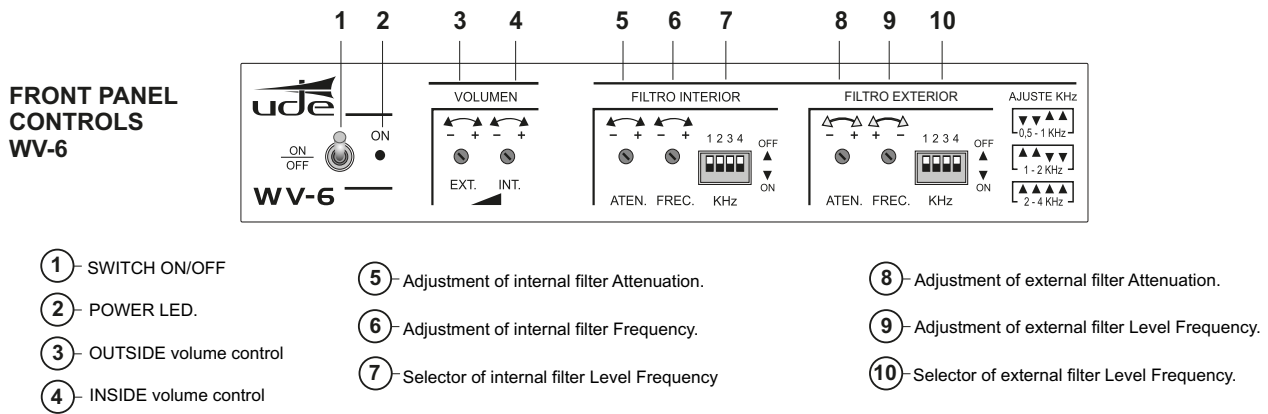

START-UP PROCEEDURE

An assistant is required on the other side.

The noise level condition inside and outside the ticket office should be those of normal use.

Position all the adjustment potentiometers on the front and rear panel to the minimum (counter-clockwise)

Turn the WV-6 central unit on via the "ON/OFF" switch. The red ON light will light up.

Press the start button on the PZ-39V microphone. The associated green LED should light up.

Press the external volume adjustment, speaking normally in front of the indoor microphone, until the appropriate level is reached outside. Then, proceed in the same way with the indoor volume speaking from the outside, the indoor level should be appropriate to the environment.

If at the set level the sound tends to be coupled, this is usually due to the model of speaker used as well as the acoustic characteristics of the room.

In this case it will be necessary to adjust the indoor and outdoor filters.

FILTERS ADJUSTMENT PROCEDURE

Adjustment of the outdoor filter:

- 1.- Slightly reduce the indoor volume.
- 2.- Increase the outdoor volume up to the critical point of coupling and activate the adjustment of the filter attenuation to the maximum and readjust the frequency. If it has no effect, change the frequency range until you achieve a noticeable improvement on the sound.

Adjustment of the indoor filter:

Increase the outdoor volume up to the critical point of coupling and activate the adjustment of the filter attenuation to the maximum and readjust the frequency. If it has no effect, change the frequency range until you achieve a noticeable improvement on the sound.

A fine adjustment is possible by reducing attenuation.

Once both filters have been adjusted, readjust the inner and outer volumes to the appropriate levels.

The system is the adjusted.

MAGNETIC LOOP ADJUSTMENT (WV-10 accessory)

Adjust the volume on the rear panel until the loop modulation indicator lights up when speaking in front of the indoor microphone.

IV-6/M system composition

IV-5

OUTDOOR MICROPHONE

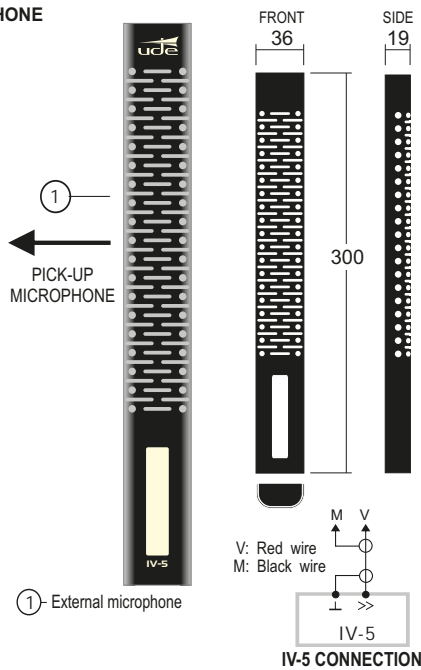

WEIGHT= 300 grams.
DIMENSIONS IN MILLIMETRES

IV-5 microphone installation

- 1- Fix the outdoor speaker in place.
It should be facing the listener.
- 2- Fixing the IV-5 microphone.
 - The outdoor microphone is attached tightly to the glass by means of the special adhesive incorporated in it.
 - To fix it correctly, proceed as follows:
 - A- Degrease the surface of the glass where the microphone is to be attached, using isopropyl alcohol or similar.
 - B- Use a suitable marker to mark the position of the external microphone IV-5.
 - C- Remove the protective adhesive tape from the back of the IV-5 microphone housing and press it into position against the glass.

Properties of the adhesive:

- Temperature range from -30°C to +90°C
- Adhesive force:
 - Tensile strength: 59 N/cm².
 - Shear: 48 N/cm².
- The adhesive is instantaneous. Once the microphone is installed, all the installation operations can be carried out. However, the adhesive reaches its maximum resistance after 48 hours.
- Application temperature: 18°C. or higher.

- 3- Proceed to connect the cables according to the connection diagram.

IV-6/M Connection

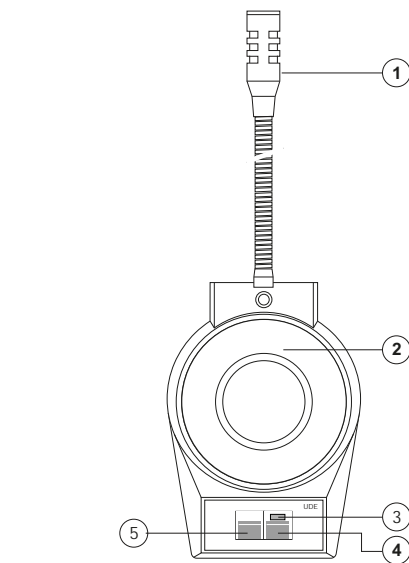

- 1- Indoor microphone
- 2- Indoor speaker
- 3- ON light indicator (green)
- 4- ON pushbutton.
- 5- OFF pushbutton.

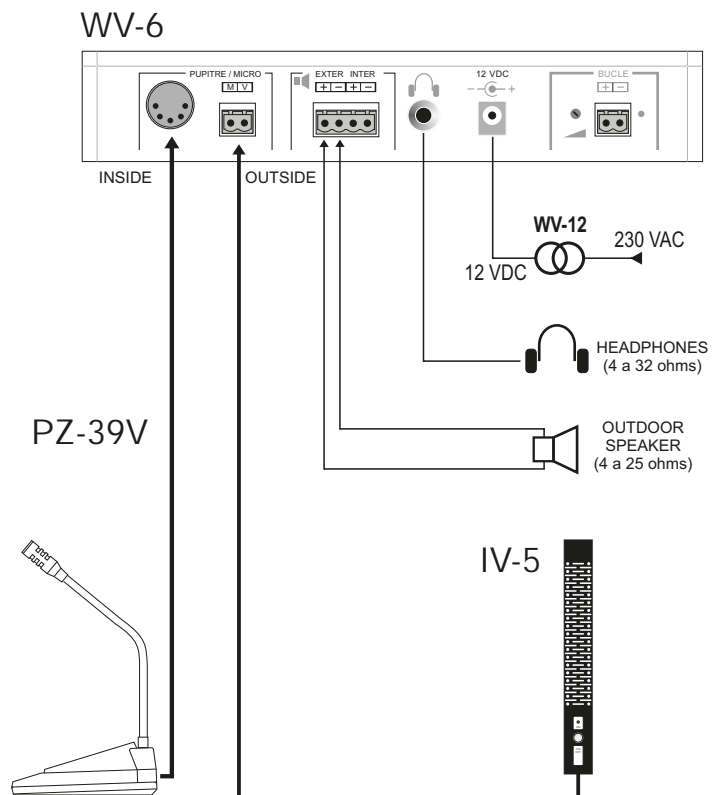
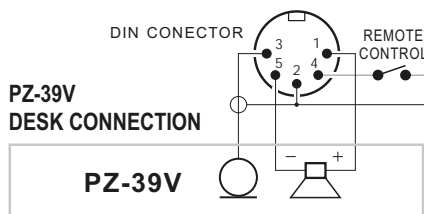

*Cable for PZ-39V and IV-5 connection supplied. Length: 3 meters.

Recommended layout for IV-6/M System

A – OUTDOOR SPEAKER IV-5

B – ACOUSTIC BOX AP-700

C – CEILING SPEAKER

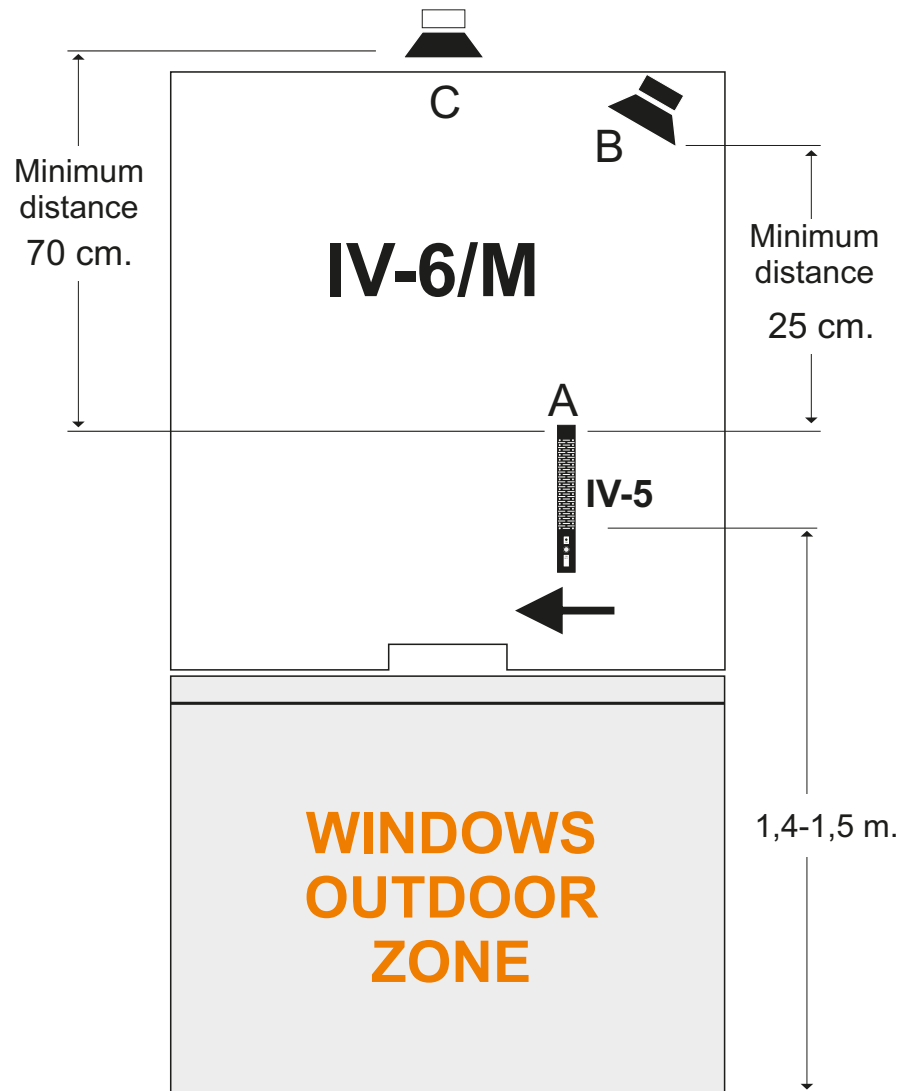

Microphone in position A.

Speaker in position B o C.

The arrow indicates the direction microphone pick-up.