

CM-23

Hand-held microphone

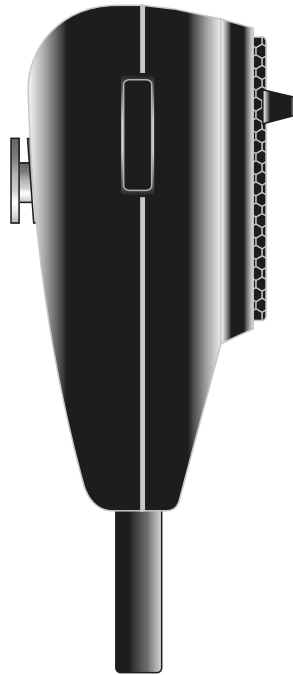

- Hand-held microphone fitted with noise cancellation device, specially designed for application in marine and industrial sites.
- Robust, reliable, shock-proof and resistant to high level of temperature as well as high degree of humidity.
- Corrosion resistant cabinet.
- Fitted with XLR connector (5 pins), compatible with master intercom stations UDE ID-500 serie.
- Spiroidal cable 2,5 meters long.
- Speech push-button built-in.
- **Accessory delivered:** Clip allowing wall mounting facilities.
- **Accessory optional:** Wall base connection (WM-58).

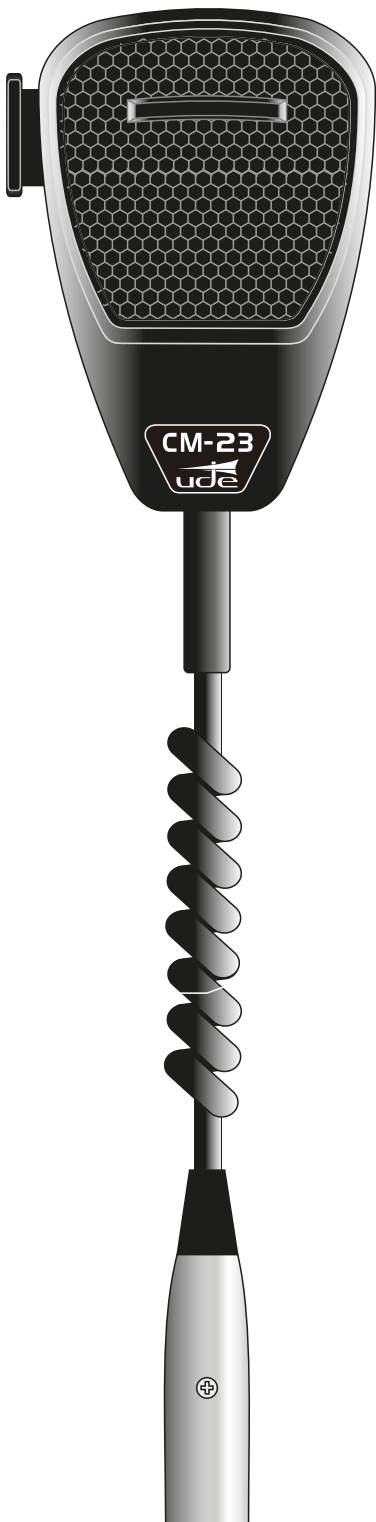
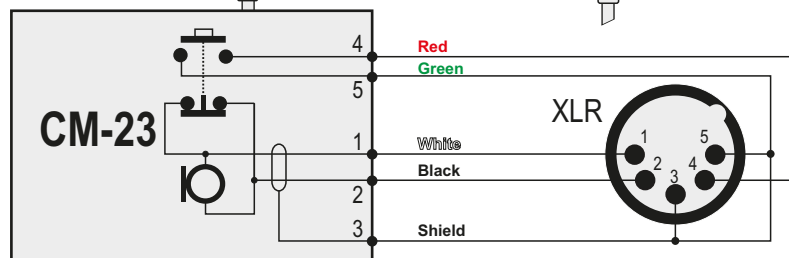
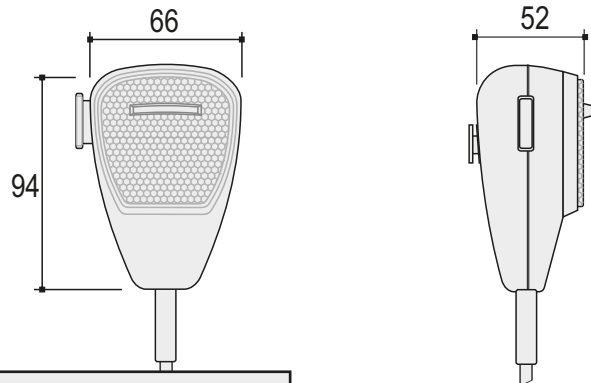

TECHNICAL FEATURES

- Sensitivity:	-66 dBV/Pa.
- Frequency range:	100 a 5000 Hz.
- Impedance:	200 ohms.
- Operation temperature:	de -40° hasta +75°C.
- Weight:	250 grammes.



EQUIPOS Y SISTEMAS MEGAFONÍA/INTERCOM • PUBLIC ADDRESS SYSTEMS

UNIÓN DESARROLLOS ELECTRÓNICOS

Tel.: +34 934 772 854 / +34 609 914 787 • ude@udeaudio.com • BARCELONA - SPAIN

www.udeaudio.com

rev.0 | 610.257a | 1 / 1