

Main characteristics

- ✓ Class D 120W RMS power amplifier.
- ✓ Volume and tone control for each input.
- ✓ Five MIC / AUX (line) configurable audio inputs (balanced / unbalanced).
- ✓ One RCA unbalanced AUX (line) audio input.
- ✓ One XLR balanced 0 dBm audio output.
- ✓ +12Vdc phantom power in MIC1 - MIC2- MIC3 - MIC4 - MIC5
- ✓ Audio filters (music and voice) in MIC1 - MIC2- MIC3 - MIC4 - MIC5
- ✓ Five trigger inputs with MIC / AUX (LINE) 1-2-3-4-5 for priority control and mute options.
- ✓ WX-19 - WXD-19 compatible.
- ✓ Loudspeaker terminal 4 ohm / L70V / L100V
- ✓ -10 dB attenuation option for each input.
- ✓ WXD-19 configuration jumpers
- ✓ Compatible with UDE priority modules WX-17 / WX-30 / WX-34 / WX-36 / WX-37
- ✓ 230VAC (50/60Hz) power supply
- ✓ Dimensions: 427 x 86 x 312 mm (2U high)

Description

The **AXD-129** amplifier have five configurable MIC / AUX (line) (both balanced) input, volume and bass / treble control en each input.

The new amplifier range AXD had been designed with class D amplifiers, trying to achieve the lowest power consumption and increasing the global features.

Compatible with all the UDE equipments range: Power amplifiers, preamplifiers, microphones, loudspeakers, function cards, feedback suppressor...

Due of use of digital signal amplifiers (class D) the power consumption is less and the power amplifiers have greatest features.

UDE Mechanical and electronic design is based in the criteria of functionality, tough and reliability as is needed in the professional sound applications. Thanks to its standardized dimensions (standard 19", 2U), might be easy installed with other UDE sound equipments or other musical sources. Installation could be compact in the same rack cabinet.

Functions

Inputs 1-2-3-4-5: MIC / AUX (LINE)

MIC / AUX (LINE) inputs also have phantom supply (+12V), speech filter configuration. All input have an individual bass and treble control.

Input 6: AUX (LINE)

Input with bass and treble control.

CONTROL INPUT MANAGEMENT

Control inputs should be connected with an euroblock terminal.

- **Inputs 1, 2, 3 and 4:** Every of these audio inputs have a direct relation with the control input that works with the euroblock connector. Connection is done between control input and ground.

- **Input 5:** The AXD-129 has an internal electronic muting, that works with control input 1, 2, 3 or 4.

- **Input 6:** The AXD-129 has an internal electronic muting, that works with control input 5.

The **AXD-129** has internal terminals to connect different UDE function cards; **WX-30** chime and input priorities, **WX-33** input priority 1, **WX-34** priority chime and 4 programmable inputs, **WX-36** priority activated by modulation detection, **WX-37** detection of universal modulation.

OUTPUT SIGNAL 0dBm / OUTPUT CONTROL

One audio connector (XLR) for output symmetric signal (+6dBu).

The output control closes the contact to ground, when the input controls 1, 2, 3, 4 or 5 is active. The output control is useful when the amplifier is associated to other equipments with function cards that allow using priority functions, priority relays and more.

CLASS DAMPLIFIER

Class D processors have better performance and less equipment dissipation in order to decrease the power consumption.

-10dB ATTENUATION

All audio inputs (1 to 6) can have the configuration with jumpers to apply an additional attenuation of -10dB. This feature in order to have a more precise regulation of the frontal control volume, if is necessary.

FEEDBACK SUPPRESSOR

The **AXD-129** has the option to connect the **WXD-19** (digital automatic feedback suppressor + limiter) inside the power amplifier. Also can accept the **WX-19** and need to be configured with internal jumpers.

RACK MOUNTING

The brackets for 2 U modules (**WX-2**) will be needed.

Technical characteristics

- Output power:	120 W. RMS.
- Impedance:	4 ohms.
- Voltage output:	L70V (41Ω) - L100V (83Ω).
- Distortion (THD):	Less than 0,5%.
- Frequency response:	50 Hz. to 15 KHz.
- Power supply:	230 VAC (50/60 Hz.).
- Max power consumption:	175 VA.
- Tone controls:	Bass control: 100 Hz.± 10 dB. Treble control: 10 KHz.± 10 dB.
- Dimensions:	427 x 86 x 312 mm. (2 U).
- Color:	Black.
- Weight:	9,6 Kgs.

Inputs 1 - 2 - 3 - 4 - 5 MIC / AUX (line) XLR connector

microphone: sensitivity = 2 mV.
impedance = 600 Ω .
phantom supply = 12 VDC

line: sensitivity = 200 mV.
impedance = 100 KΩ.

Input 6 AUX (line) RCA connector

line: sensitivity = 200 mV.
impedance = 100 KΩ.

Line output 0 dBm with trigger control. XLR connector

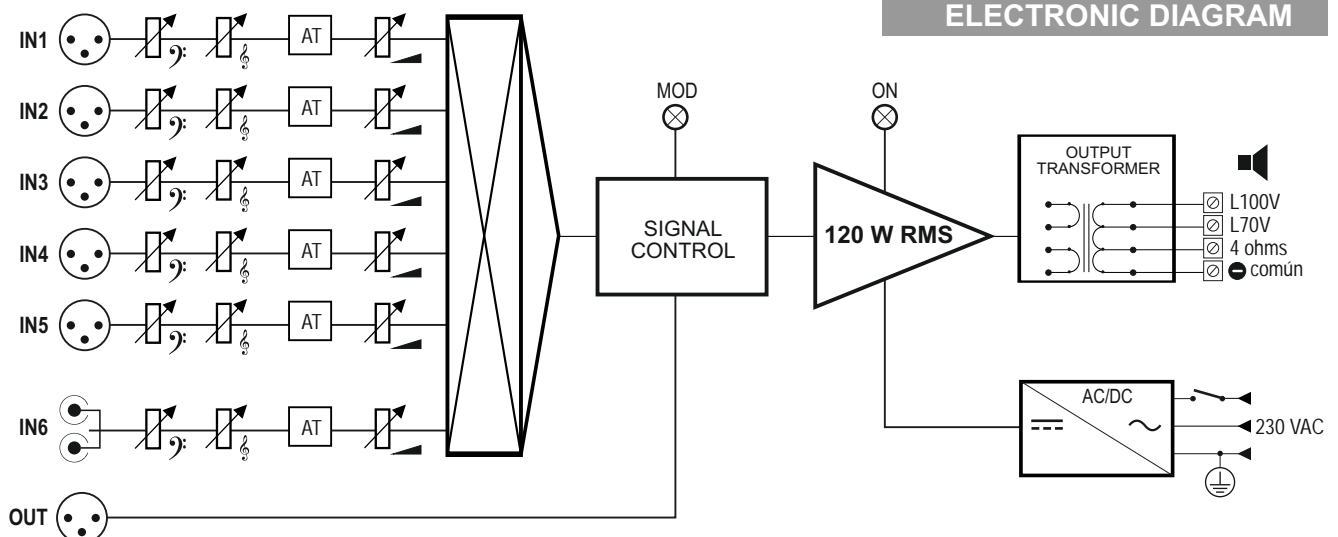

Front panel

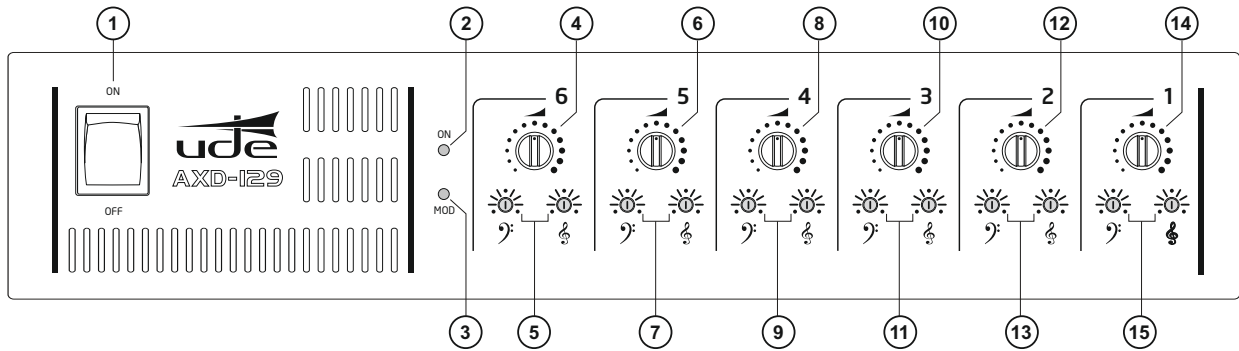

- ① Power switch ON / OFF.
- ② Power led indicator.
- ③ LED level meter.
- ④ Input 6 volume control.
- ⑤ Input 6 bass / treble control.
- ⑥ Input 5 volume control.
- ⑦ Input 5 bass / treble control.
- ⑧ Input 4 volume control.
- ⑨ Input 4 bass / treble control.
- ⑩ Input 3 volume control.
- ⑪ Input 3 bass / treble control.
- ⑫ Input 2 volume control.
- ⑬ Input 2 bass / treble control.
- ⑭ Input 1 volume control.
- ⑮ Input 1 bass / treble control.

Rear panel

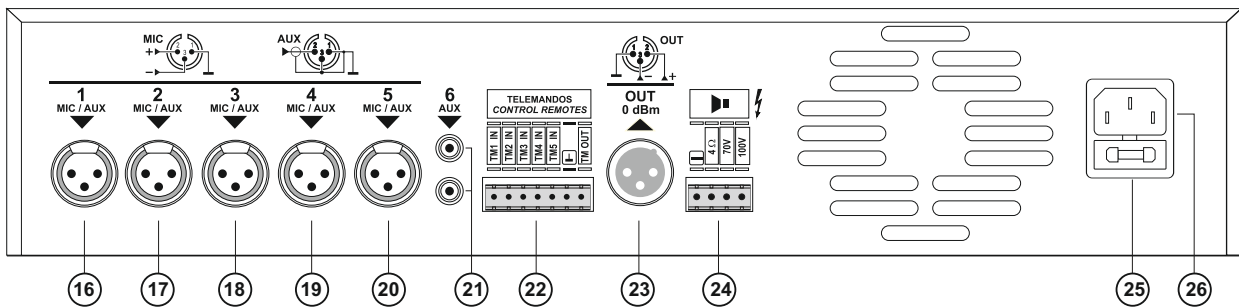

- ①⑥ Audio socket 1 mic / aux (line) (XLR).
- ①⑦ Audio socket 2 mic / aux (line) (XLR).
- ①⑧ Audio socket 3 mic / aux (line) (XLR).
- ①⑨ Audio socket 4 mic / aux (line) (XLR).
- ②⑦ Audio socket 5 mic / aux (line) (XLR).
- ②① Audio socket 6 aux (RCA).
- ②② Control input / output terminal.
- ②③ Audio output socket (XLR).
- ②④ Loudspeaker output 4 ohms / L70V - L100V.
- ②⑤ Fuse T 1,6A.
- ②⑥ 230 VAC supply input with built-in fuse holder.

Connections

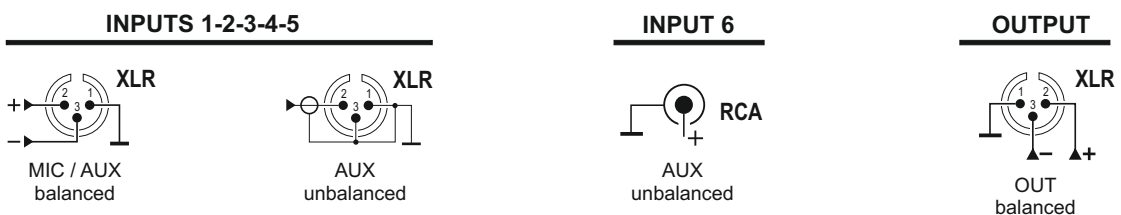

Internal settings

OPEN THE POWER AMPLIFIER AND BUT THE JUMPERS ACCORDING THE AUDIO INPUT SETTINGS DESIRED

INPUTS CONFIGURATION

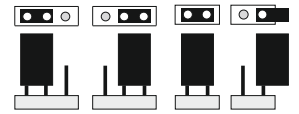
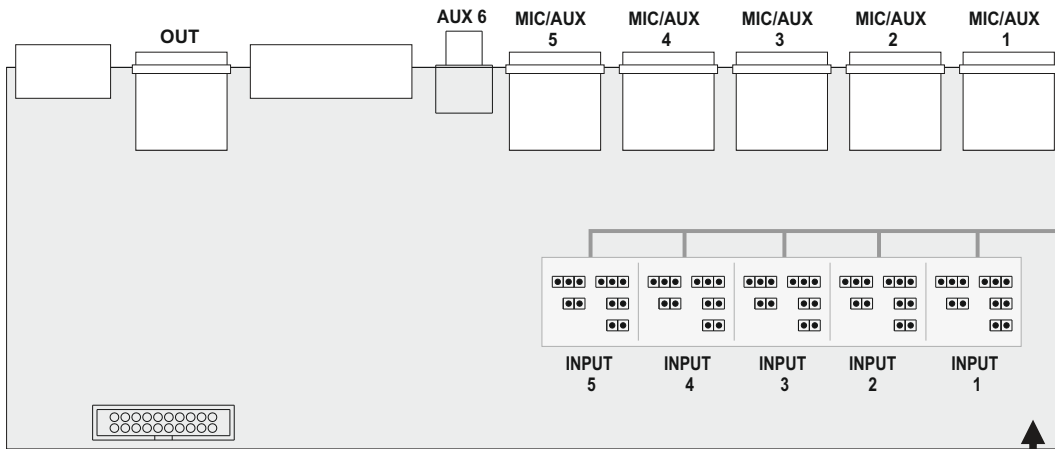

JUMPER CONFIGURATION

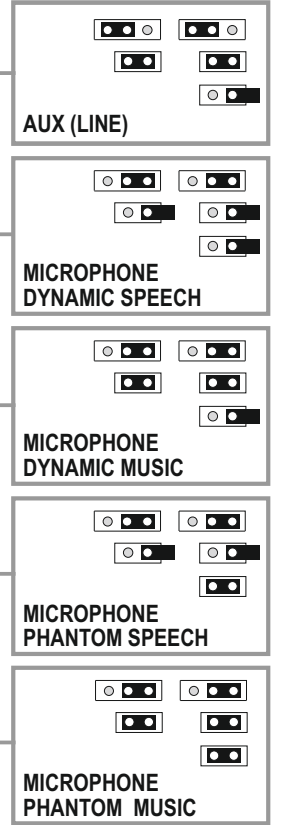

INSTALL THE **WX-19** AND REMOVE JUMPER **D**

INSTALL THE **WXD-19** AND PUT JUMPER **D** IN **A-B-C** POSITION, ADJUST THE LIMITER TOO.

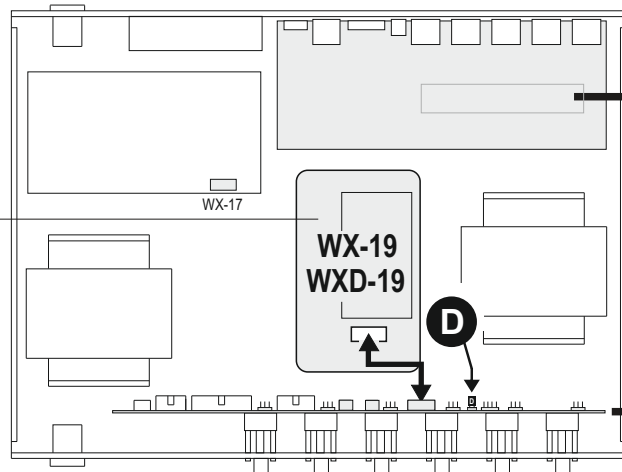

ATTENUATION CONFIGURATION

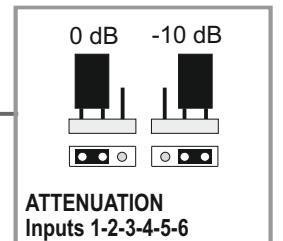
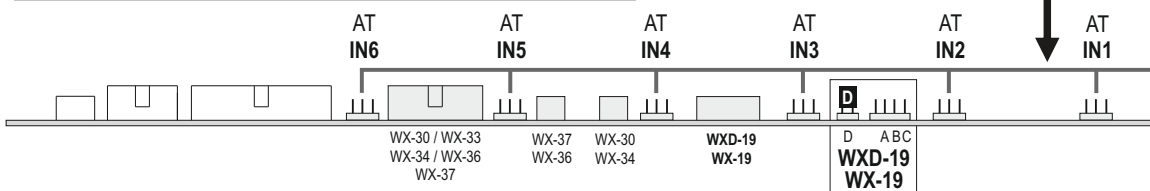

WXD-19 / WX-19 CONFIGURATION

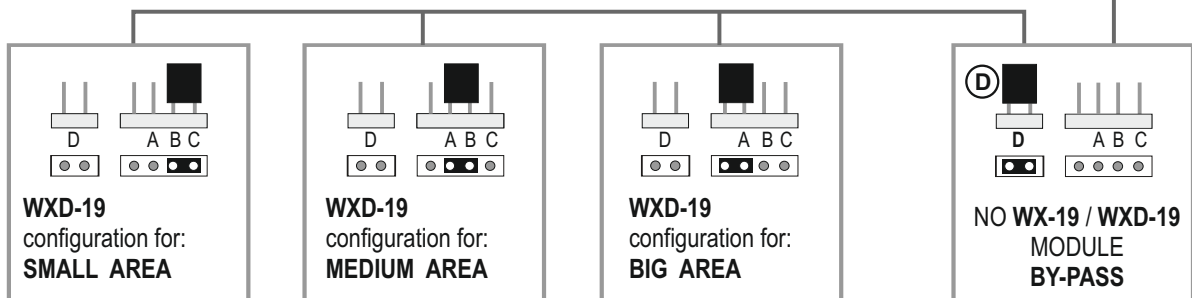

FACTORY SETTINGS:

- INPUTS 1, 2, 3, 4, 5 and 6: MICROPHONE PHANTOM SPEECH
- ATTENUATION INPUTS 1, 2, 3, 4, 5 and 6: 0 dB.