

# AP-700



## CAJA ACÚSTICA ENCEINTE ACOUSTIQUE WALL MOUNT SPEAKER



### CARACTERÍSTICAS TÉCNICAS

Diámetro altavoz:	3".
Potencia:	3W / L100V.
Respuesta de frecuencia:	200 Hz a 9 KHz.
Presión acústica:	88 dB (1 W / 1 m / 1 KHz).
Color:	ABS / Blanco Ral 9010.
Peso:	420 gr.

### CARACTERISTIQUES TECHNIQUES

Diamètre haut-parleur:	3".
Puissance nominale:	3W / L100V.
Bande passante:	200 Hz à 9 KHz.
Pression acoustique:	88 dB (1 W / 1 m / 1 KHz).
Matière / couleur:	ABS / Blanc Ral 9010.
Poids:	420 gr.

### TECHNICAL CHARACTERISTICS

Speaker diameter:	3".
Rated power:	3W / L100V.
Frequency range:	200 Hz to 9 KHz.
Sensitivity:	88 dB (1 W / 1 m / 1 KHz).
Material / colour:	ABS / Ral White 9010.
Weight:	420 gr.

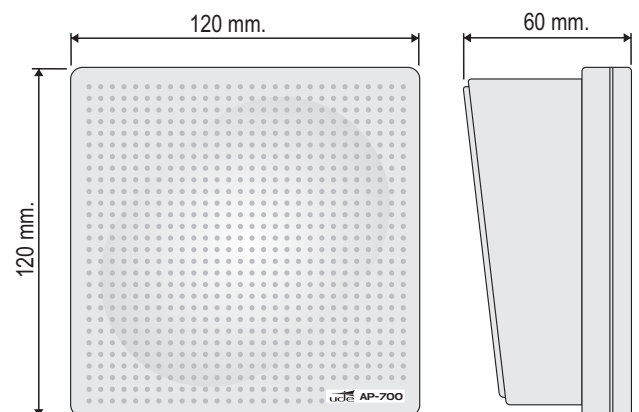
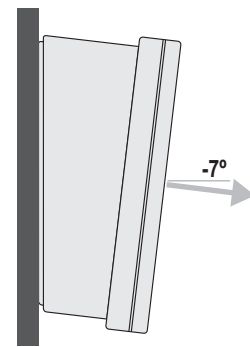
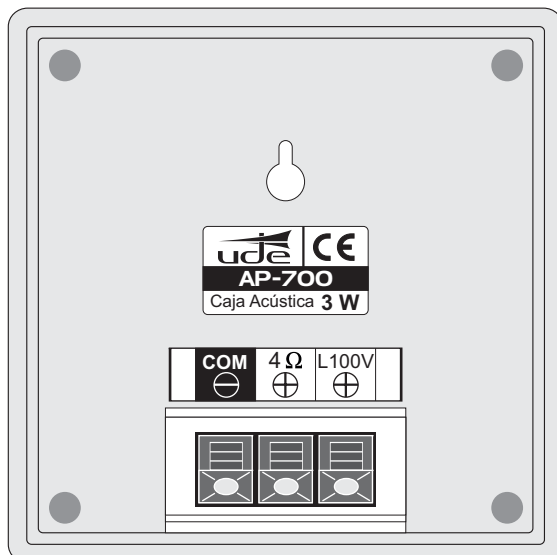

EQUIPOS Y SISTEMAS MEGAFONÍA / INTERCOM • PUBLIC ADDRESS SYSTEMS

UNIÓN DESARROLLOS ELECTRÓNICOS

Tel.: +34 934 772 854 / +34 609 914 787 • ude@udeaudio.com • BARCELONA - SPAIN



[www.udeaudio.com](http://www.udeaudio.com)

rev.0 610.357CFA 1 / 1