

WM-102

Adaptador micrófono
Microphone adapter

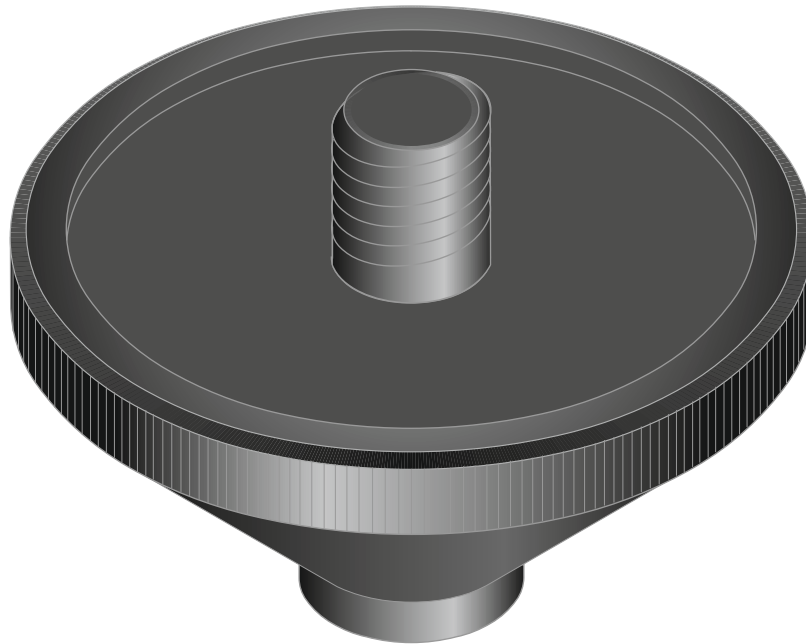

EJEMPLOS DE MONTAJE ASSEMBLY EXAMPLES

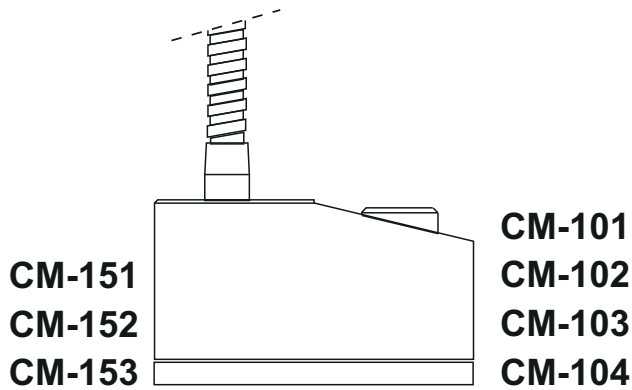

WM-102

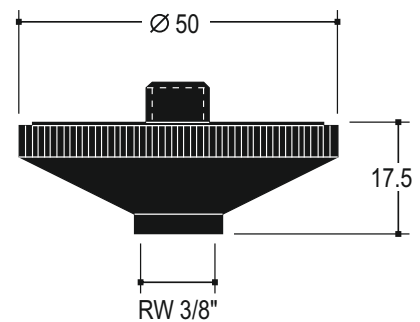
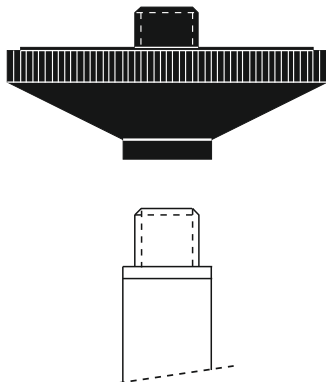

MEDIDAS EN MILIMETROS
PESO = 150 gr.
COLOR = **WM-102: Negro**

MEASUREMENTS IN MILLIMETRES
WEIGHT = 150 g.
COLOUR = **WM-102: Black**



EQUIPOS Y SISTEMAS MEGAFONÍA / INTERCOM • PUBLIC ADDRESS SYSTEMS
UNIÓN DESARROLLOS ELECTRÓNICOS

Tel.: +34 934 772 854 / +34 609 914 787 • ude@udeaudio.com • BARCELONA - SPAIN

www.udeaudio.com

rev.0 | 610.038ca | 1 / 1