

DESCRIPTION

INTERCOM-500 System enables optical and audible signalling of calls made from different zones and to establish two-way intercom spoken between each intercom and the central.

SYSTEM FUNCTIONS

- **Standard call** with appeal brief.
- **Visual and acoustic signaling in the standard call** control central.
- **Cancellation of the standard call center.**
- **Transfer the management of calls between the control centrals.**
- **Transfer calls management to a DECT telephone or a switchboard**, by module IW-18 (**optional**).
- **Standard sound call** of control central by an external amplifier (**optional**).

INTERCOMS PARTNERS INTERCOM-500 SYSTEM

The system allows the connection of two types of intercoms:

- Intercommunication with previous line and 100 V line transformer by modules IW-510A and IW-520A.
- Intercommunication low impedance (passive) by modules IW-510P and IW-520P.

SYSTEM COMPOSITION

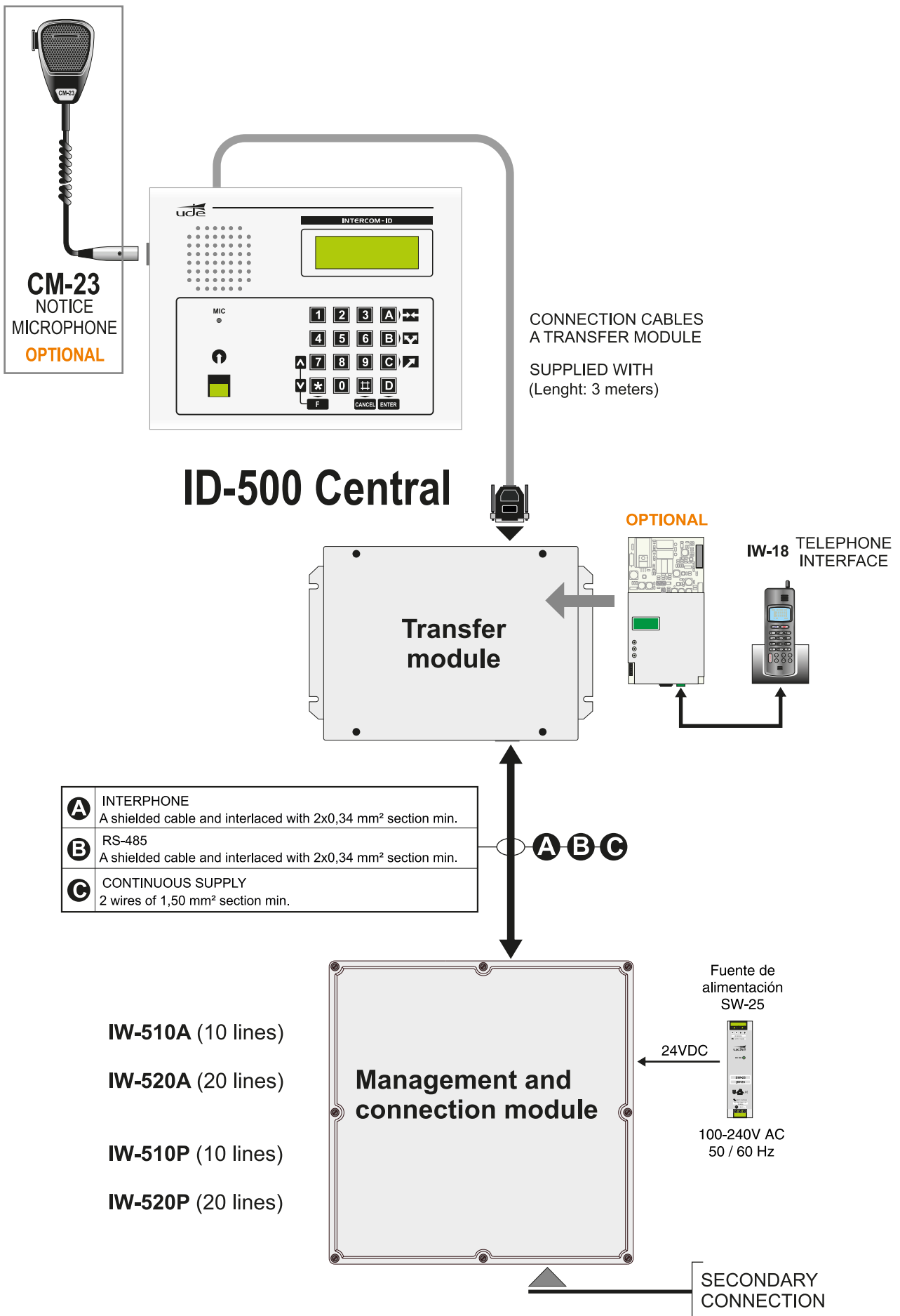

DIMENSIONS / ACCESSORIES

ID-500 Central

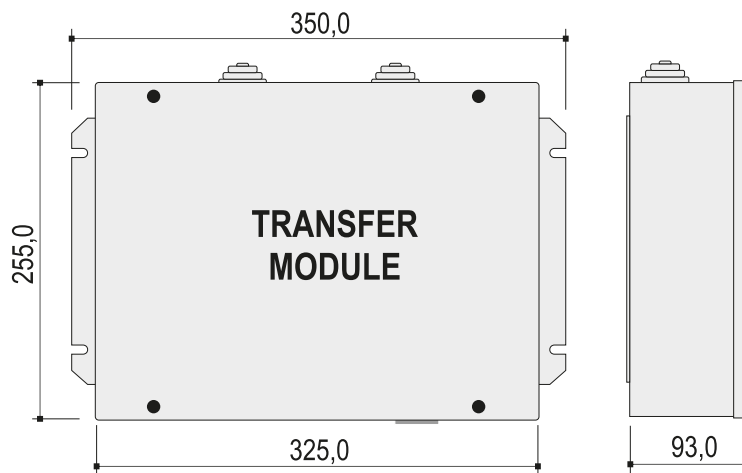
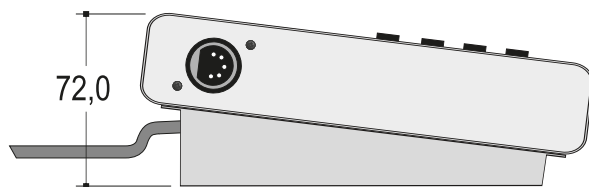
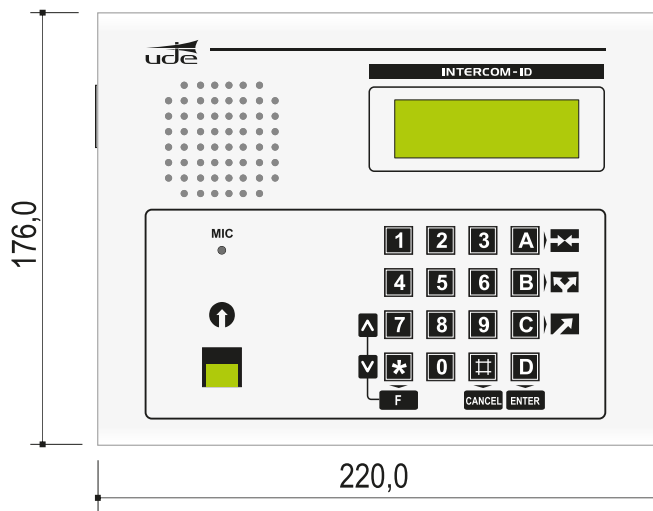
**Control central point ID-500 office format, with:**

Selection of lines and functions keyboard.

Alphanumeric LCD display backlit 4 x 20 characters. Built-in electret microphone.

Connector for notice microphone CM-23.

Speaker of receipt.

Setting the reception level and the acoustic tone of appeal level.

Visual and acoustic signalling calls.

Visual indication of the selected area.

Alphanumeric keyboard.

Its main function is call signalling and management made in different rooms and intercommunication with them as well.

Supplied with Transfer Module.

By the **UdeConf ID-500** software you can configure in the ID-500 central the following parameters:

- Name and ID number of the ID-500 desk.
- Name of each zone.
- Extension number of each zone.
- Zones assigned to each desk.
- Floor / Group situation zone.
- Name of each zone to give the message by telephone interface.

DIMENSIONS / ACCESSORIES

ACCESSORIES (OPTIONAL) ID-500 Central

TELEPHONE INTERFACE

IW-18 telephone interface.

It allows you to forward calls to a two threads phone (type DEC) or a PBX to manage incoming calls in the ID-500 central diverted to the phone. Each ID-500 central can support one IW-18 module.

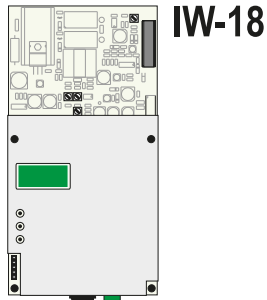

PTT MICROPHONE

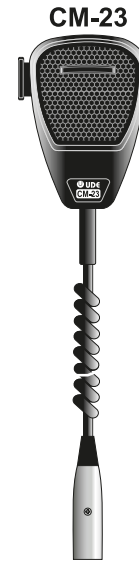

FRAMEWORK FOR BUILD-IN ID-500 CENTRAL

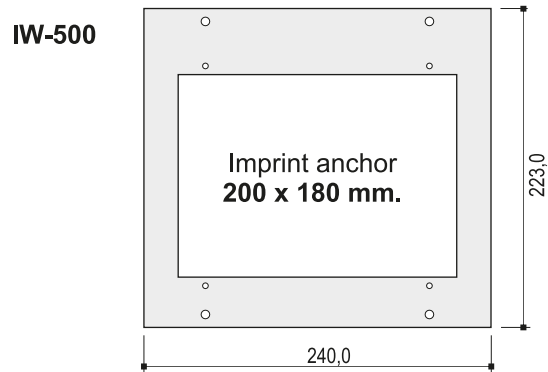

BUILD-IN ID-500 CENTRAL (in RACK 19")

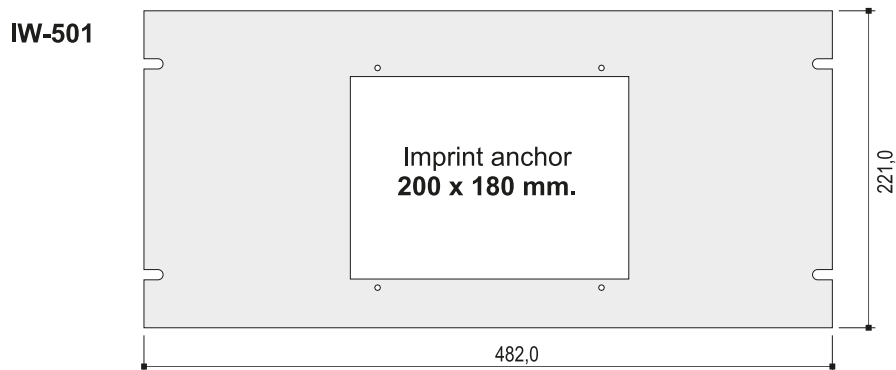

DIMENSIONS / ACCESSORIES

MANAGEMENT, TRANSFER AND CONNECTION MODULE

IW-510A (10 lines) / **IW-520A** (20 lines)
INTERPHONES WITH PREVIOUS LINE

IW-510P (10 lines) / **IW-520P** (20 lines)
LOW IMPEDANCE INTERPHONES

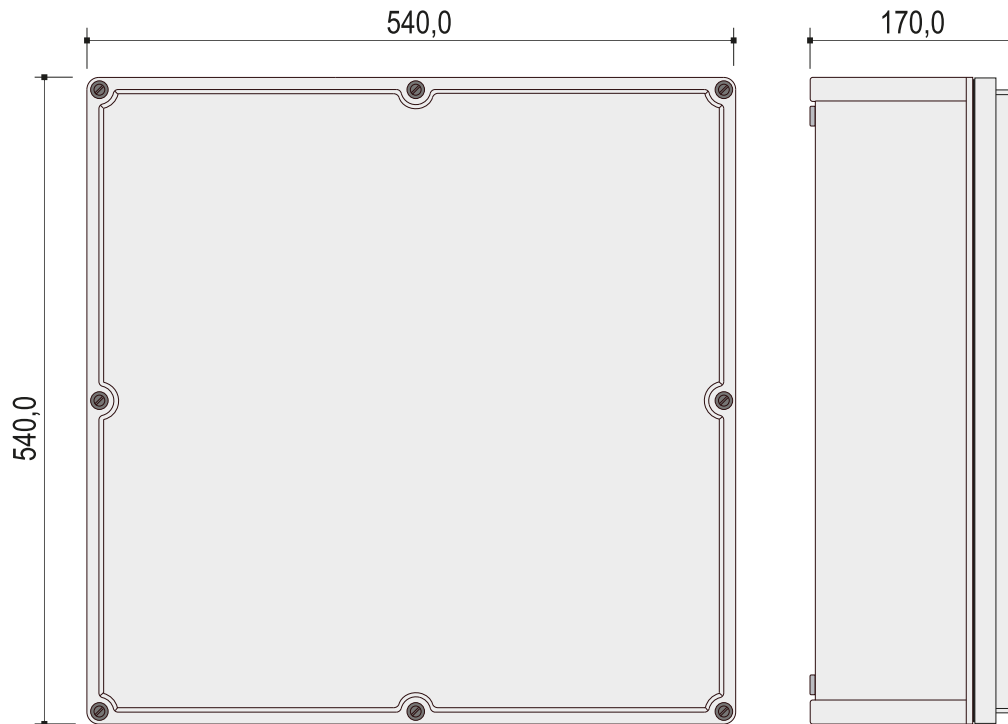

DEGREE OF PROTECTION: IP-66



SIDE INDUSTRIAL connection Range UDE	
IW-510A / IW-520A	IW-510P / IW-520P
IR-62/1 IR-62/2 IR-62/3 SI-60	IR-62/P

ACCESSORIES (OPTIONNAL)

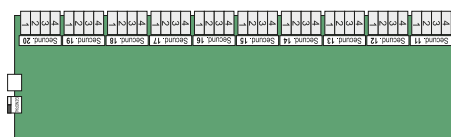

IW-10A Extension card 10 lines
 Allows increasing module **IW-510A** to 20 lines

IW-10P Extension card 10 lines
 Allows increasing module **IW-510P** to 20 lines

SYSTEM OPTIONS

