

AP-840EN

Two-Way Acoustic Box



EN54-24

- ✓ Commercial PA system wall mount speaker with transformer.
- ✓ Ideal for school, offices, hotel, airports, etc.
- ✓ Compliant with the EN54-24 standards.
- ✓ Impact-resistant & UV-resistant ABS plastic housing.
- ✓ IP55 rated against adverse weather conditions.
- ✓ Integrated thermal fuse, 95°C fire-resistant cable and fire resistant dome.
- ✓ Power outputs 40W / 20W / 10W / 5W + 8 Ohms with power selector.
- ✓ Quick installation by supplied stainless mounting bracket.



Technical specifications

Model	AP-840EN
Description	Two-way acoustic box
Power output	40W / 20W / 10W / 5W + 8Ω
Line input	100V / 70V
Frequency response	100-20KHz
SPL(@1W/m)	90dB
Speakers	6.5" woofer & 1.5" tweeter
Dimensions	310×213×195mm
Material	ABS plastic housing with metal grill.
Installation	"U" stainless mounting bracket.
Weight	3.7kg

Technical reference: WSK-640HEN

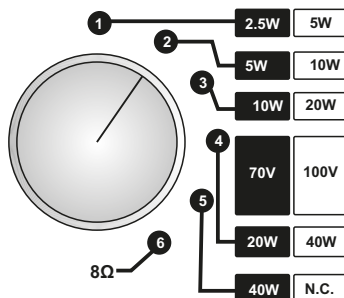
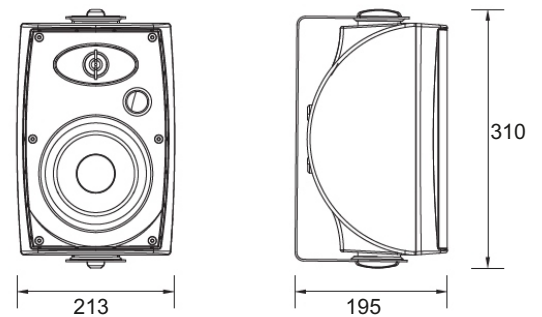

Warning: If the loudspeaker is connected to L100V, do not set the switch to position 5 and 6 under any circumstances. It will cause damage to the loudspeaker and the power amplifier to which it is connected.



EQUIPOS Y SISTEMAS MEGAFONÍA/ INTERCOM • PUBLIC ADDRESS SYSTEMS
UNIÓN DESARROLLOS ELECTRÓNICOS

Tel.: +34 934 772 854 / +34 609 914 787 • ude@udeaudio.com • BARCELONA - SPAIN

www.udeaudio.com

rev.2 | 610.560A | 1 / 1