

AP-820EN

Two way wall mount speaker



EN54-24

- ✓ Commercial PA system wall mount speaker with transformer.
- ✓ Ideal for school, offices, hotel, airports, etc.
- ✓ Compliant with the EN54-24 standards.
- ✓ Impact-resistant & UV-resistant ABS plastic housing.
- ✓ IP55 rated against adverse weather conditions
- ✓ Integrated thermal fuse, 95°C fire-resistant cable and fire resistant cone.
- ✓ Power outputs 20W / 10W / 5W / 2.5W + 8Ω with power selector.
- ✓ Quick installation by supplied stainless mounting bracket.



Technical specifications

Model	AP-820EN
Description	Two Way Acoustic Box
Power output	20W / 10W / 5W / 2.5W + 8Ω
Line Output	100V / 70V or 8Ω
Frecuency Response	100-20KHz
SPL(@1W/m)	88dB
Speakers	4" woofer and 1" tweeter
IP Rate	IP55
Dimensions	245×170×140mm
Material	ABS plastic housing with metal grill in white.
Installation	"U" stainless mounting bracket
Weight	2.5kg

Technical reference: WSK-420HWEN

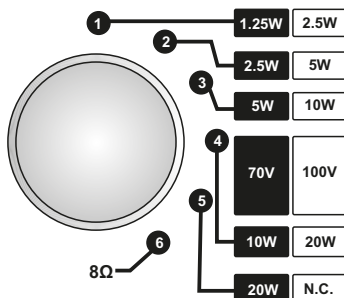
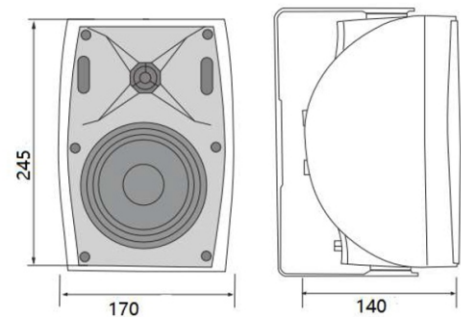

Warning: If the loudspeaker is connected to L100V, do not set the switch to position 5 and 6 under any circumstances. It will cause damage to the loudspeaker and the power amplifier to which it is connected.



EQUIPOS Y SISTEMAS MEGAFONÍA/ INTERCOM • PUBLIC ADDRESS SYSTEMS
UNIÓN DESARROLLOS ELECTRÓNICOS

Tel.: +34 934 772 854 / +34 609 914 787 • ude@udeaudio.com • BARCELONA - SPAIN

www.udeaudio.com

rev.2 | 610.634A | 1 / 1