

CSB-516

16 zones emergency call signal central

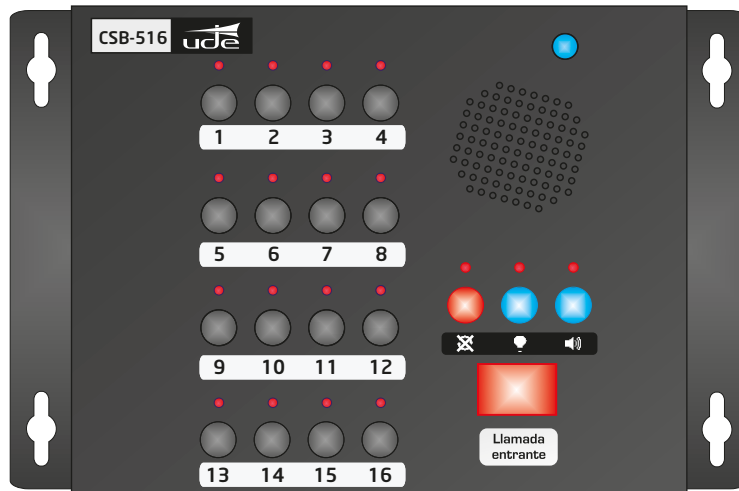

Description

Compact 16-zone call signalling control panel compatible with SB-504 emergency call signalling modules.

When the call is activated from the SB-504 modules, the system emits an audible and visual warning both in the bathroom area and at the associated control panel. The call can be muted by pressing the cancel button from the SB-504 bathroom module or from the CSB-516 control panel.

The system is powered by 24 VDC from an external power supply. It incorporates an NO contact that remains closed as long as there is one or more active calls.

Easy to install and simple to use. Can be mounted horizontally or vertically.

Dimensions

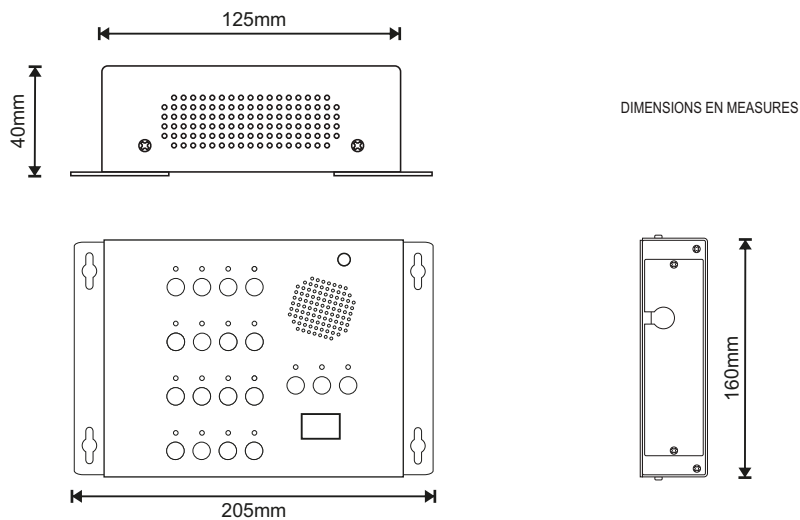

EQUIPOS Y SISTEMAS MEGAFONÍA / INTERCOM • PUBLIC ADDRESS SYSTEMS

UNIÓN DESARROLLOS ELECTRÓNICOS

Tel.: +34 934 772 854 / +34 609 914 787 • ude@udeaudio.com • BARCELONA - SPAIN

www.udeaudio.com

rev.1 | 610.566A | 1 / 3

Front panel

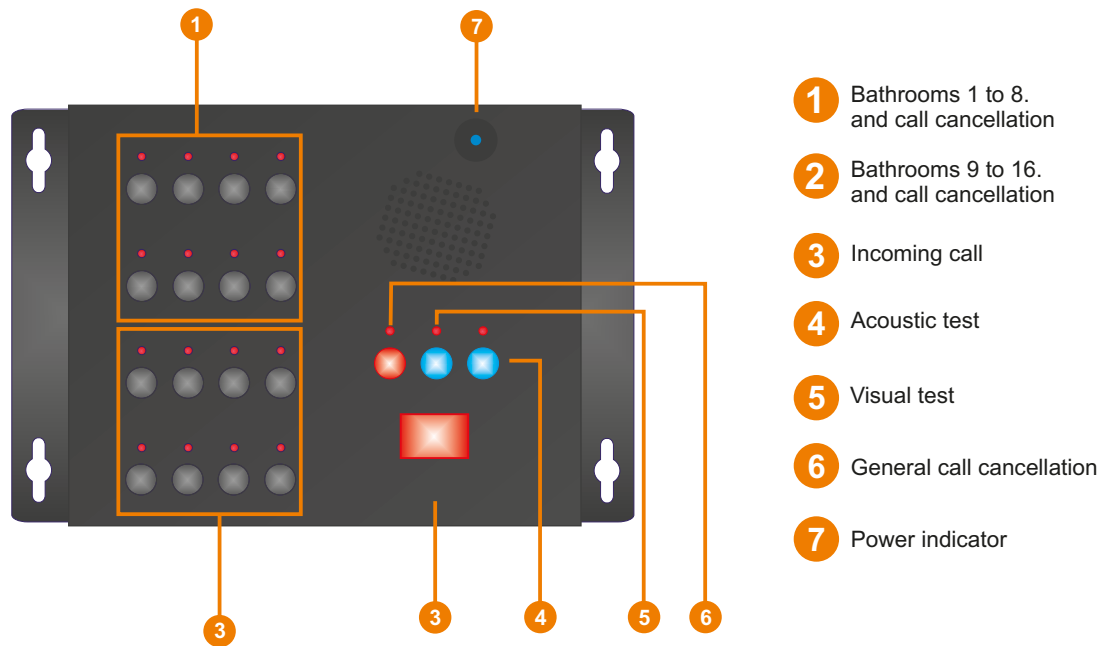

Rear panel

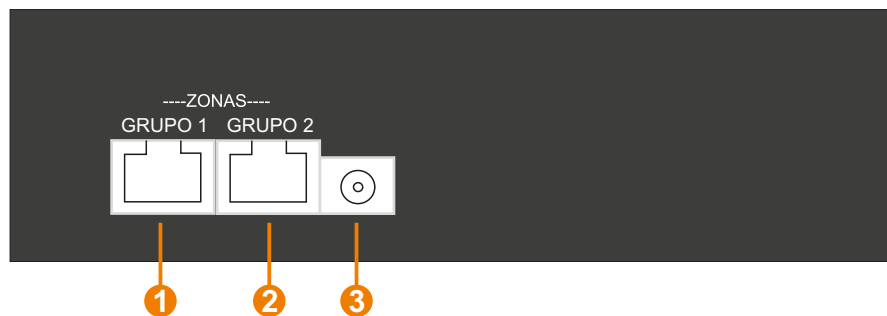

- 1 RJ45 inputs to zones 1 to 4 and 9 to 12
- 2 RJ45 inputs to zones 5 to 8 and 13 to 16
- 3 24V DC Input

Connection diagram

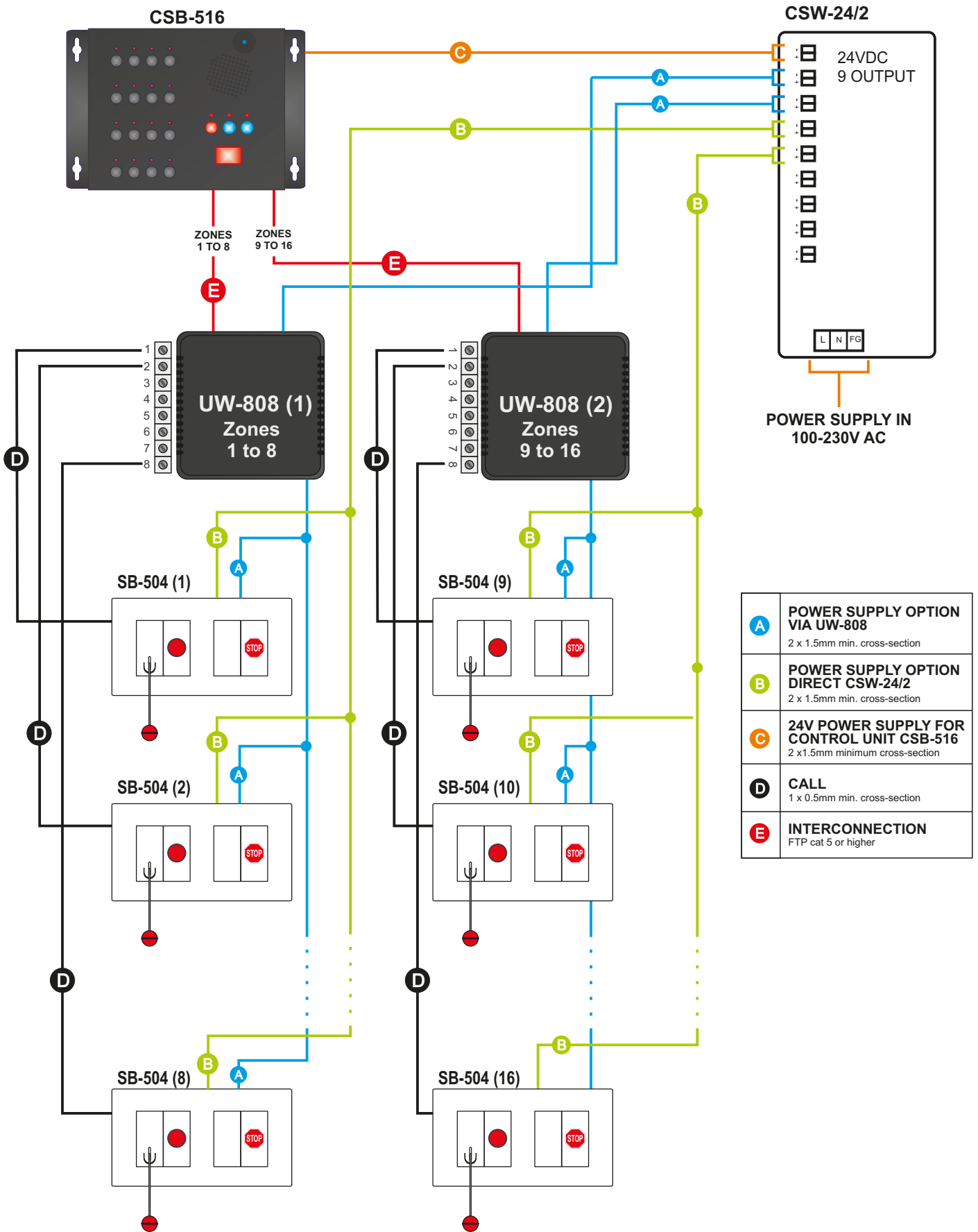

A	POWER SUPPLY OPTION VIA UW-808 2 x 1.5mm min. cross-section
B	POWER SUPPLY OPTION DIRECT CSW-24/2 2 x 1.5mm min. cross-section
C	24V POWER SUPPLY FOR CONTROL UNIT CSB-516 2 x 1.5mm minimum cross-section
D	CALL 1 x 0.5mm min. cross-section
E	INTERCONNECTION FTP cat 5 or higher