

(RACK 19" / 2 U.)



DESCRIPCION

El módulo puesta en marcha **UDE PM-21** está diseñado para montaje en rack de 19" y ocupa una altura de 2U. Su empleo es de gran utilidad en instalaciones de megafonía de pequeña, media y gran potencia.

Mediante el interruptor de red incorporado, permite la puesta en marcha general de todos los elementos instalados en el rack.

Un piloto luminoso indica claramente el estado del conjunto (ON/OFF).

DESCRIPCION

UDE PM-21 "On/Off" mains power panel has been specially designed for 19" rack monitoring facilities (2U high). This unit is very useful for little, medium and big power public address systems.

Thanks to the mains switch, it is possible to put the power on, for all the products built-in the rack, at the same time.

One lamp informs clearly the status of the Public address system (ON/OFF).

CARACTERÍSTICAS TÉCNICAS

- Intensidad nominal a 230 VAC:	6 A. 16 A (*).
- Conexionado:	Bornes a tornillo.
- Sección máxima del cable:	2.5 mm ² .
- Piloto indicador "ON":	Neón rojo.
- Peso:	2.8 Kg.

(*) -Para aquellos aparatos que incorporen dispositivo limitador de corriente de puesta en marcha, como los amplificadores **UDE** modelos **EP-400**, **AX-309**, y **AX-459**, se considerarán como carga resistiva.

TECHNICAL CHARACTERISTICS

- Nominal current to 230 V-AC:	6 A. 16 A (*).
- Connection:	Screw terminals.
- Max. cable section:	2.5 mm ² .
- Indicator lamp "ON":	Red Neon.
- Weight:	2.8 Kg.

(*) -For the products with built-in current limiter, when they are powered on, such as amplifiers **UDE** models **EP-400**, **AX-309**, **AX-459**, they will be considered as resistive load.

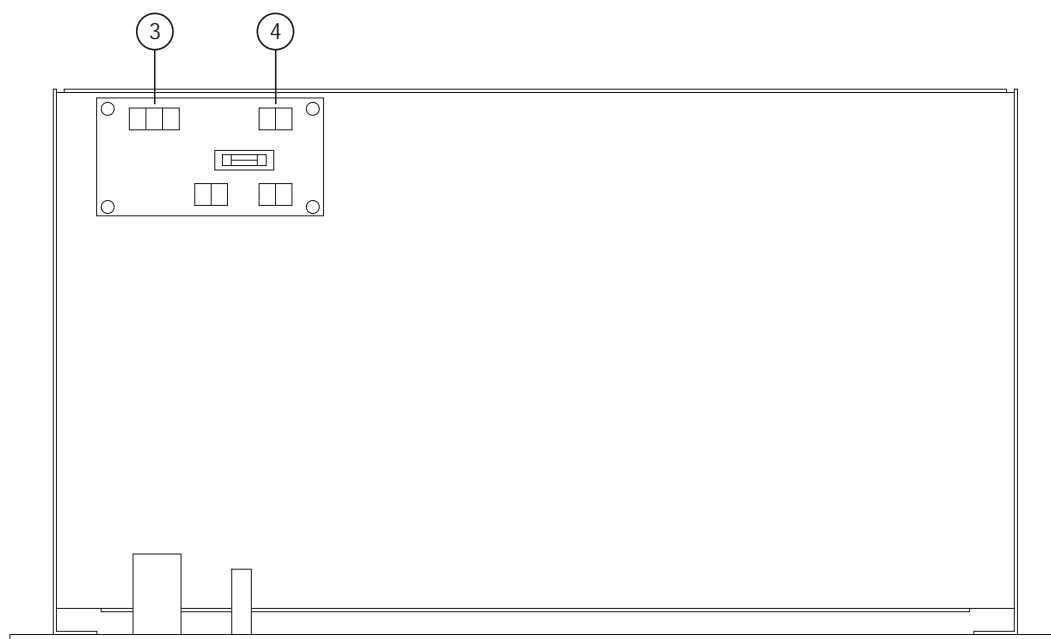
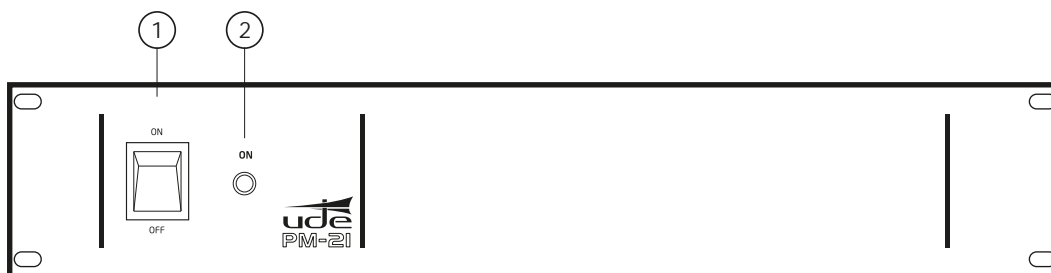

- | | |
|--|---|
| ① Interruptor marcha | ① Mains switch |
| ② Piloto marcha | ② Indicator lamp |
| ③ Bornas entrada red (230 VAC) | ③ Mains input block terminals (230 VAC) |
| ④ Bornas salida alimentación (230 VAC) | ④ Power supply output block terminals (230 VAC) |

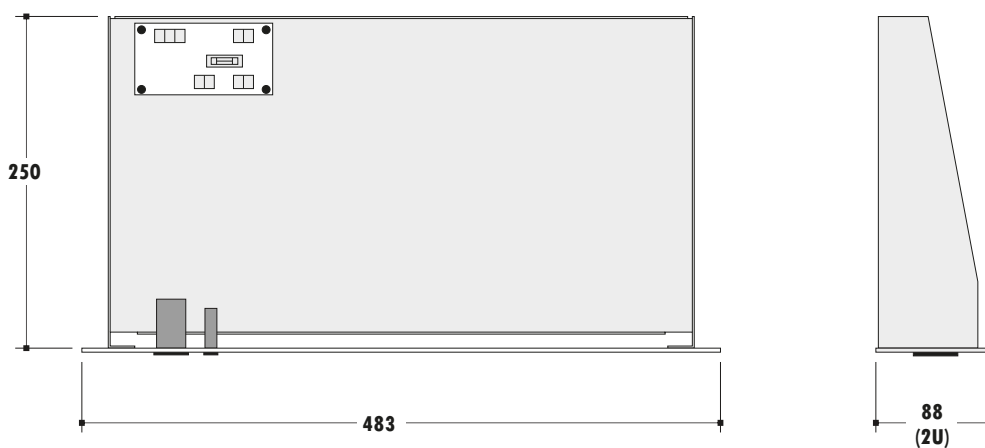

MEDIDAS EN MILIMETROS

DIMENSIONS IN MILLIMETRES



INSTALACION:

- 1- Montar el módulo **PM-21** en el rack. (Normalmente en la parte superior).
- 2- Conectar los conductores de protección (tierra), fase y neutro, siguiendo la normativa de seguridad aplicable en cada caso, y en cada país.
- 4- Conectar la salida de 230 VAC del interruptor del panel **PM-21** a los diferentes aparatos del rack, mediante los accesorios de distribución adecuados en cada caso (bases, derivaciones, contactores, etc).
- 5- Finalizado el conexionado, proceder a montar los elementos de cierre del rack, comprobando que los elementos de protección estén correctamente instalados.
- 6- Dar alimentación 230 VAC. El sistema quedará listo para su uso.

UTILIZACION:

- 1- Accionar el interruptor de puesta en marcha. Comprobar que todos los pilotos indicadores "ON" se iluminan.

INTALLATION

- 1- Install panel **PM-21** inside the rack (generally on the top of the rack).
- 2- Connect power supply cable (Earth / Phase / Neuter) according with security regulations applicable in each specific case and in each country.
- 3- Connect power supply output (230V-AC) to the different products installed inside the rack, thanks to a special distribution accessories which may be required, such as derivators, contactors, etc.)
- 4- When all the connections have been completed, install all the accessories required in order to close the rack.
- 5- Check that mains power supply, 230V-AC is available. The Public Address system is ready to operate.

OPERATION

- 1- Put Mains switch "ON". Check that all the indicator lamps are "ON".

DIAGRAMA CONEXIONADO
CONNECTION DIAGRAM

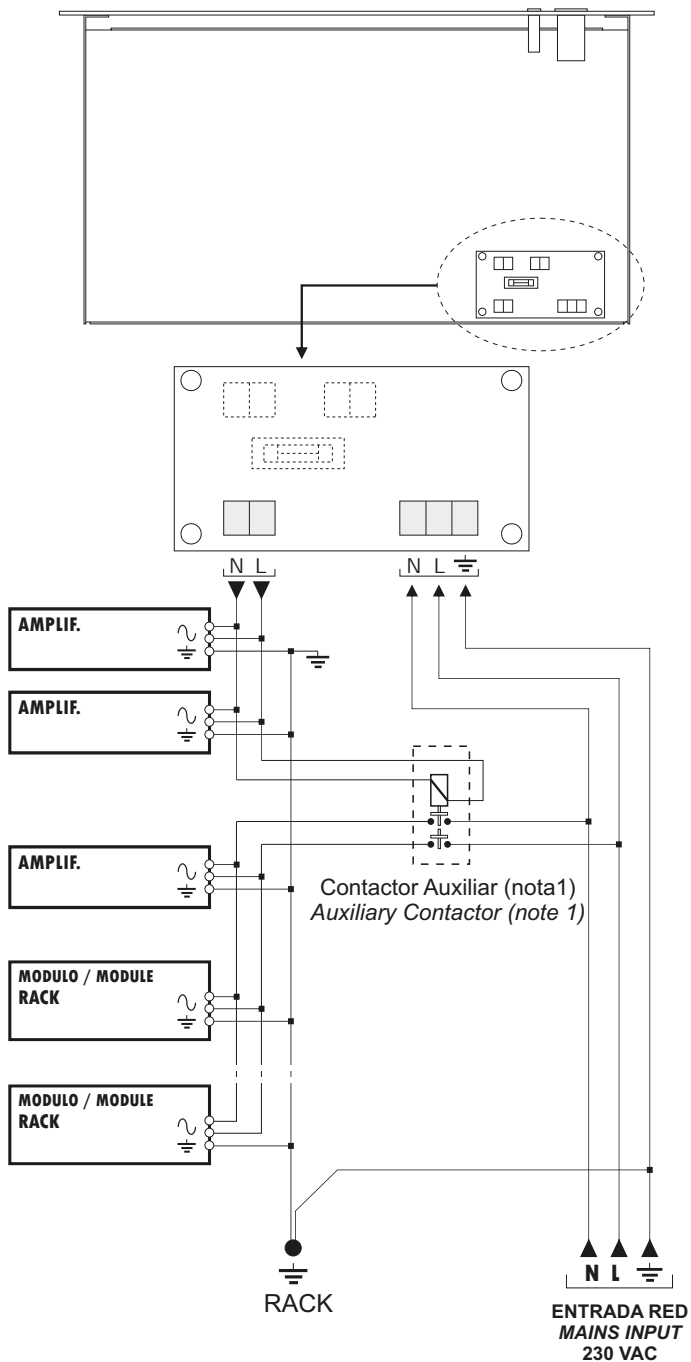

Nota 1:

- En función del consumo de los aparatos montados en el rack, puede ser necesario instalar contactores auxiliares.

Note 1:

- According to the consumption of some products installed inside the rack, it may be necessary to install auxiliary contactors.